

## A Variable Concept for the Preparation of Branched Glycosyl Phosphatidyl Inositol Anchors

Klaus Pekari and Richard R. Schmidt\*

Fachbereich Chemie, Universität Konstanz, Fach M725, D-78457 Konstanz, Germany

richard.schmidt@uni-konstanz.de

Received August 31, 2002

A variable concept for the synthesis of branched glycosyl phosphatidyl inositol (GPI) anchors was established. Its efficiency could be shown by the successful synthesis of the GPI anchor of *rat brain* Thy-1 and of the *scrapie* prion protein both in the water soluble **1c** and lipidated form **1a**. Retrosynthesis led to building blocks **2–6** of which **5** could be further disconnected to building blocks **7–9**. Trichloroacetimidate **5** was built up in a straightforward manner starting from glycosyl acceptor **9** using known glycosyl donors **7** and **8**. The carbohydrate backbone was then assembled by glycosylation of pseudodisaccharide acceptor **6** with donor **5**. To ensure high stereoselectivity and good yields in the glycosylation reactions, anchimeric assistance was employed. Successive deprotection and introduction of the various phosphate residues gave the fully protected GPI anchors. Catalytic hydrogenation and acid-catalyzed cleavage of the Boc protecting groups afforded the target molecules, which could be fully structurally assigned.

### Introduction

Glycosyl phosphatidyl inositol (GPI) anchors are a class of naturally occurring glycolipids that link proteins and glycoproteins via their C-terminus to eukaryotic cell membranes. The first full structural assignment of a GPI anchor was published in 1988 by Ferguson et al.<sup>1,2</sup> Since then quite a few anchors have been characterized, allowing the definition of a common core structure, which is highlighted in Scheme 1.<sup>3,4</sup> This common core structure, present in a wide variety of species, is conserved during evolution while there are a lot of species-specific variations in the branching groups of the glycan residue (R<sup>2</sup>-R<sup>4</sup>). Additional ethanolaminephosphate groups (R<sup>1</sup>) on the central mannose residue seem to be specific for higher eukaryotes. Another modification site is the lipid anchor where various structures can be found.

The function of GPI anchors has been extensively discussed and there is evidence that, besides the obvious one of anchoring proteins to membranes, there are a lot of different functions of GPI anchors and/or metabolites of them. For example, GPI anchoring of a protein seems to signal transport to certain areas of the cell membrane.<sup>5,6</sup> One of the most controversial aspects of GPI anchors is their ability to mediate signaling mechanisms

or to function as second messengers, e.g. in insulin-mediated signal transduction processes.<sup>7</sup> Therefore, to perform biological studies elucidating the functions of GPI anchors, it seems to be an important objective to have access to structurally homogeneous GPI anchors and their derivatives. For the total synthesis of GPI anchors, a combination of lipid, phosphate, and oligosaccharide chemistry is required. This has been successfully carried out for a ceramide-containing GPI anchor of yeast<sup>8,9</sup> and for the acylglycerol-containing GPI anchors of *Trypanosoma brucei*<sup>10,11</sup> and *rat brain* Thy-1.<sup>12</sup>

The aim of this work was the development of a highly variable synthetic strategy for the preparation of branched GPI anchors. This strategy should also allow the attachment of peptide residues and (naturally occurring) proteins to the anchor. All GPI syntheses published so far do not take into consideration the attachment of a peptide residue nor the variability required for the preparation of practically all types of GPI anchors. We focused on 4,6-branched GPI anchors as there are several prominent examples found in nature. In a first approach we synthesized the fully phosphorylated pseudohexasaccharide

(1) Ferguson, M. A. J.; Homans, S. W.; Dwek, R. A.; Rademacher, T. W. *Science* **1988**, *239*, 753–759.

(2) Homans, S. W.; Ferguson, M. A. J.; Dwek, R. A.; Rademacher, T. W.; Anand, R.; Williams, A. F. *Nature* **1988**, *333*, 269–272.

(3) Frankhauser, C.; Homans, S. W.; Oates, J. E.; McConville, M. J.; Desponds, C.; Conzelmann, A.; Ferguson, M. A. J. *J. Biol. Chem.* **1993**, *268*, 26365–26374.

(4) Striepen, B.; Zinecker, C. F.; Damm, J. B. L.; Melgers, P. A. T.; Gerwing, G. J.; Koolen, M.; Vliegthart, J. F. G.; Dubremetz, J.-F.; Schwarz, R. T. *J. Mol. Biol.* **1997**, *266*, 797–813.

(5) Rothberg, K. G.; Heuser, J. E.; Donzell, W. C.; Ying, Y.-S.; Glenney, J. R.; Anderson, G. W. *Cell* **1992**, *68*, 673–682.

(6) Varma, R.; Mayor, S. *Science* **1992**, *394*, 802–805.

(7) Caro, H.-H.; Martin-Lomas, M.; Bernabé, M. *Carbohydr. Res.* **1993**, *240*, 119–131.

(8) Mayer, T. G.; Kratzer, B.; Schmidt, R. R. *Angew. Chem.* **1994**, *106*, 2289–2293; *Angew. Chem., Int. Ed. Engl.* **1994**, *33*, 2177–2181.

(9) Mayer, T. G.; Schmidt, R. R. *Eur. J. Org. Chem.* **1999**, 1153–1165.

(10) Murakata, C.; Ogawa, T. *Carbohydr. Res.* **1992**, *234*, 75–91. Murakata, C.; Ogawa, T. *Carbohydr. Res.* **1992**, *235*, 95–114. The enantiomer of the naturally occurring inositol moiety was selected in this synthesis.

(11) Baeschlin, D. K.; Chaperon, A. R.; Green, L. G.; Hahn, M. E.; Ince, S. J.; Ley, S. V. *Chem. Eur. J.* **2000**, *6*(1), 172–186.

(12) Campbell, A. S.; Fraser-Reid, B. *J. Am. Chem. Soc.* **1995**, *117*, 10387–10388. The <sup>1</sup>H NMR spectrum of the material indicates the presence of some byproduct.

## SCHEME 1. General Structure of GPI Anchors (EA, ethanolamine; P, phosphate; DAG, diacylglycerol)

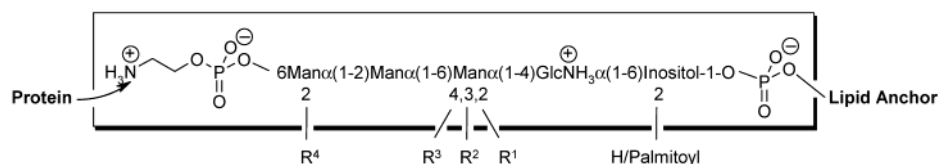

Natural Source	R <sup>4</sup>	R <sup>3</sup>	R <sup>2</sup>	R <sup>1</sup>	Lipid	Ref.
<i>S. cerevisiae</i>	Man $\alpha$ (1-2)	H	H	H	Ceramide/DAG	3
<i>T. brucei</i> VSG	H	H	Gal <sub>2-4</sub> $\alpha$ (1-3)	H	DAG	1
<i>T. gondii</i>	H	GalNAc $\beta$ (1-4)	H	H	DAG	4
Rat Brain Thy-1	Man $\alpha$ (1-2)	GalNAc $\beta$ (1-4)	H	EA-P	Acylalkylglycerol	2

of the GPI anchor of *Toxoplasma gondii*.<sup>13</sup> We now present the synthesis of the more demanding GPI anchor of *rat brain* Thy-1 which is identical with one subtype of the GPI anchors of the *scrapie* prion protein.<sup>14</sup>

This GPI anchor consists of four different  $\alpha$ -mannosyl residues, of which one is mono-, one is di-, one is tri-, and one is tetrasubstituted. It also contains an *N*-acetylgalactopyranose, a glucopyranosamine, two other free amino functions, which should be differentiated in the case of the introduction of a peptide, three different phosphate esters, and nineteen free hydroxy functions.

In a first approach we accomplished a highly convergent synthesis of the GPI anchor of *rat brain* Thy-1.<sup>15</sup> As this synthesis allowed neither the intended high variability nor the introduction of a peptide we decided to perform a different route. Main emphasis was now put on high variability in the synthesis and ready accessibility of building blocks which were already developed and optimized in earlier syntheses.

## Results and Discussion

Target molecule **1** is disconnected at positions A–C leading to phosphorus ester building blocks **2–4** and the pseudoheptasaccharide residue. This carbohydrate backbone was then disconnected at position D yielding building blocks **5** and **6**, which could further be disconnected at positions E–F to give known building blocks **7** and **8**<sup>9</sup> and disaccharide **9**.

The main emphasis in the synthesis of pentasaccharide **5** was placed on central mannose **c**, which should allow selective access to all hydroxy functions. By slight modification of the synthesis developed in this paper, access to 3,6-branched GPI anchors should also be possible. In both types of GPI anchors there can be attached additional residues in the 2-position of that particular mannose. The trichloroacetyl group was chosen as the amino protecting group in galactosamine residue **d** in order to (i) increase the electron deficiency of the amino function, thus avoiding side reactions in the glycosylation reactions, and (ii) take advantage of the

anchimeric assistance in the glycosylation reaction, thus yielding selective  $\beta$ -glycoside formation. Known mannosyl donors **7** and **8** were chosen as they provide anchimeric assistance in the glycosylation step as well as offer the possibility to install different building blocks on the terminal carbohydrate position.

One aim of the synthesis was having the potential to introduce a peptide moiety at the terminal ethanolamine residue. As the *C*-terminal amino acid residue of the naturally occurring peptide attached to the GPI anchor is cysteine, amino acid attachment has to take place after the hydrogenolytic removal of the benzyl ether protecting groups. Therefore, all amino functions, except the accessible one, had to be protected in a hydrogenation stable manner, i.e., by using Boc protection.

The introduction of the lipid anchor was planned at a very late stage in the synthesis as after that reaction the physical properties of the compounds often lead to difficult separation of byproducts. In general, also the phosphate groups should be introduced at a very late stage in the synthesis, thus providing the possibility of varying these building blocks, for example, to introduce different biological markers. With all the above-mentioned prerequisites in mind, the following synthetic concept was established.

**Synthesis of Phosphoramidite Building Blocks 2–4.** The use of the cyanoethyl protecting group in building blocks **2–4** allowed the selective deprotection of the phosphate residues on the per-*O*-benzylated oligosaccharides. This deprotection resulted in the loss of the chirality on the phosphorus atom and therefore simplified further analysis.

The preparation of lipid phosphate building block **4** started from readily available 3-*O*-benzyl-*sn*-glycerol (Scheme 3).<sup>16</sup> Activation of the primary hydroxy function of the glycerol residue with dibutylstannane and introduction of the octadecyl chain gave compound **10** with the secondary hydroxy function unprotected. Ester formation of this hydroxy group with octadecanoyl chloride in the presence of triethylamine gave intermediate **11**, which was hydrogenated over Pd/C to yield compound **12**. Then, compound **12** was subjected to phosphoramidite formation as described by Bannwarth and Treziak<sup>17</sup> to form phosphoramidite reagent **4**. *N*-Benzyloxycarbonyl

(13) Pekari, K.; Tailler, D.; Weingart, R.; Schmidt, R. R. *J. Org. Chem.* **2001**, *66*, 7432–7442.

(14) Stahl, N.; Baldwin, M. A.; Hecker, R.; Pan, K.-M.; Burlingame, A. L.; Prusiner, S. B. *Biochemistry* **1992**, *31*, 5043–5053.

(15) Tailler, D.; Ferrières, V.; Pekari, K.; Schmidt, R. R. *Tetrahedron Lett.* **1999**, *40*, 679–682.

(16) Hirth, G.; Barner, R. *Helv. Chim. Acta* **1982**, *65*, 1059–1084.

## SCHEME 2. Retrosynthesis

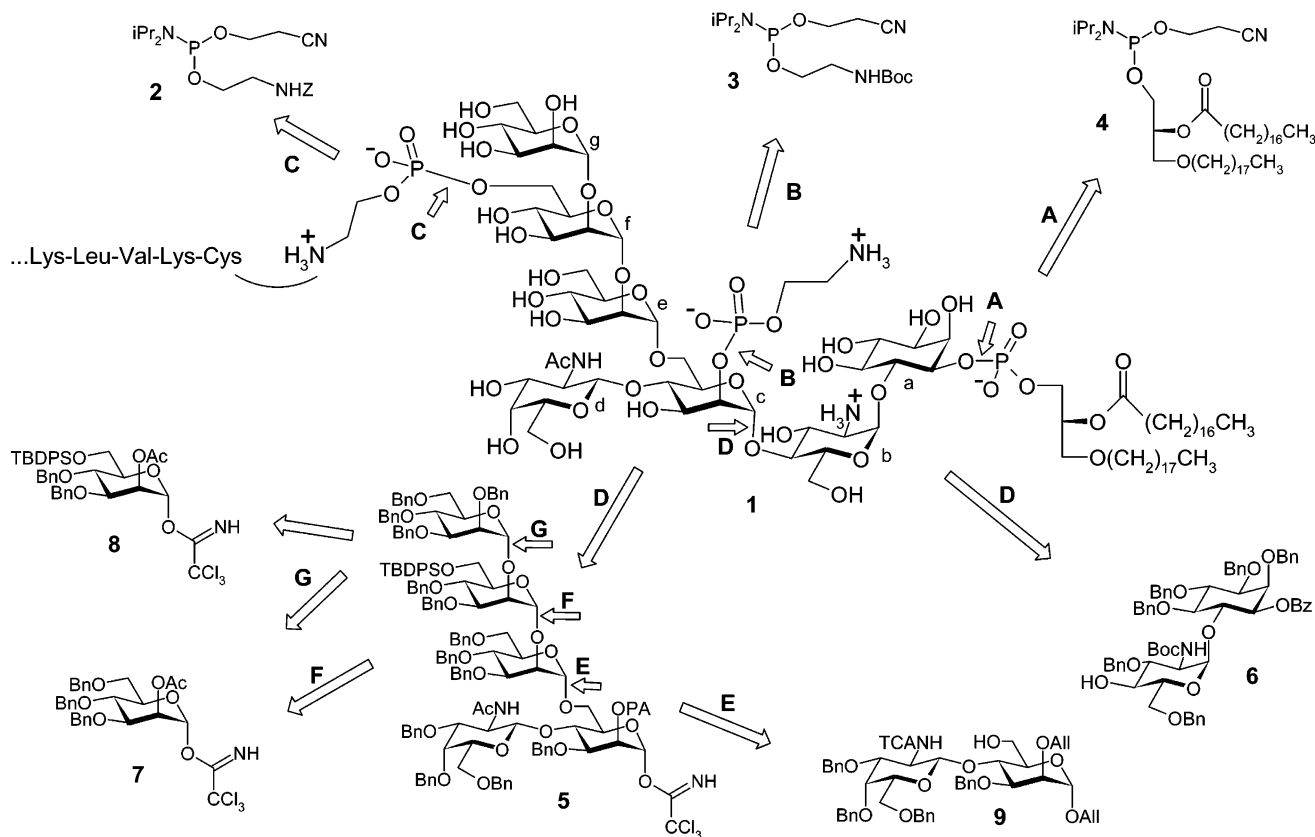

## SCHEME 3. Synthesis of Lipid Building Block 4

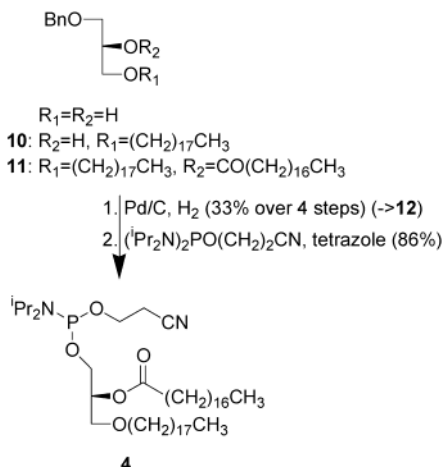

and *N*-tert-butyloxycarbonyl protected ethanolamine phosphoramidites **2** and **3** were prepared as described earlier.<sup>13</sup>

**Synthesis of Building Block 5.** The synthesis of pentasaccharide trichloroacetimidate **5** (see Schemes 4 and 5) is based on the results of the previously reported synthesis of the GPI anchor of *T. gondii*.<sup>13</sup>

Starting from known mannose derivative **13**<sup>13</sup> allylation ( $\rightarrow$ **14**) and subsequent reductive opening of the *p*-methoxybenzylidene acetal gave diallyl intermediate **15** (see Scheme 4). Glycosylation of **15** with known

## SCHEME 4. Preparation of Building Block 18

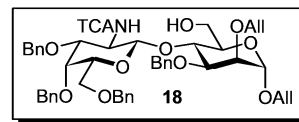
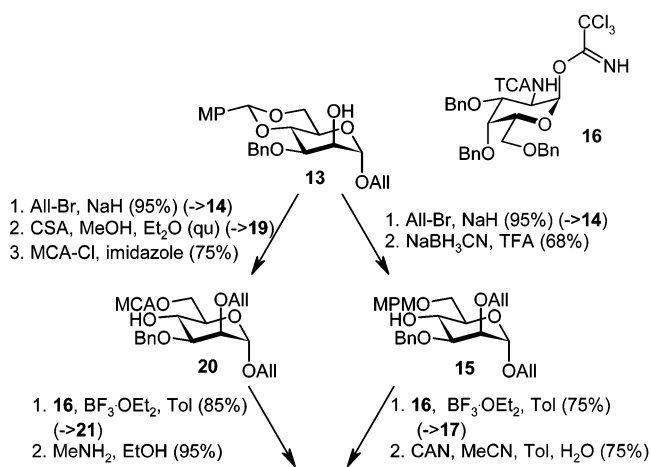

*N*-trichloroacetyl-tri-*O*-benzyl-galactosyl trichloroacetimidate **16**<sup>13</sup> under  $BF_3 \cdot OEt_2$  catalysis at  $-40^\circ C$  in toluene as solvent gave selectively  $\beta$ -disaccharide **17** in good yield.<sup>13</sup> Removal of the *p*-methoxybenzylidene group under oxidative conditions afforded disaccharide acceptor **18**. To increase the overall yield and to reduce the time for the preparation of disaccharide **18** starting from compound **13**, another pathway was developed. After allylation of compound **13** to diallyl compound **14**, the *p*-methoxybenzylidene acetal was cleaved under acidic conditions

(17) Bannwarth, W.; Treziak, A. *Helv. Chim. Acta* **1987**, *70*, 175–186.

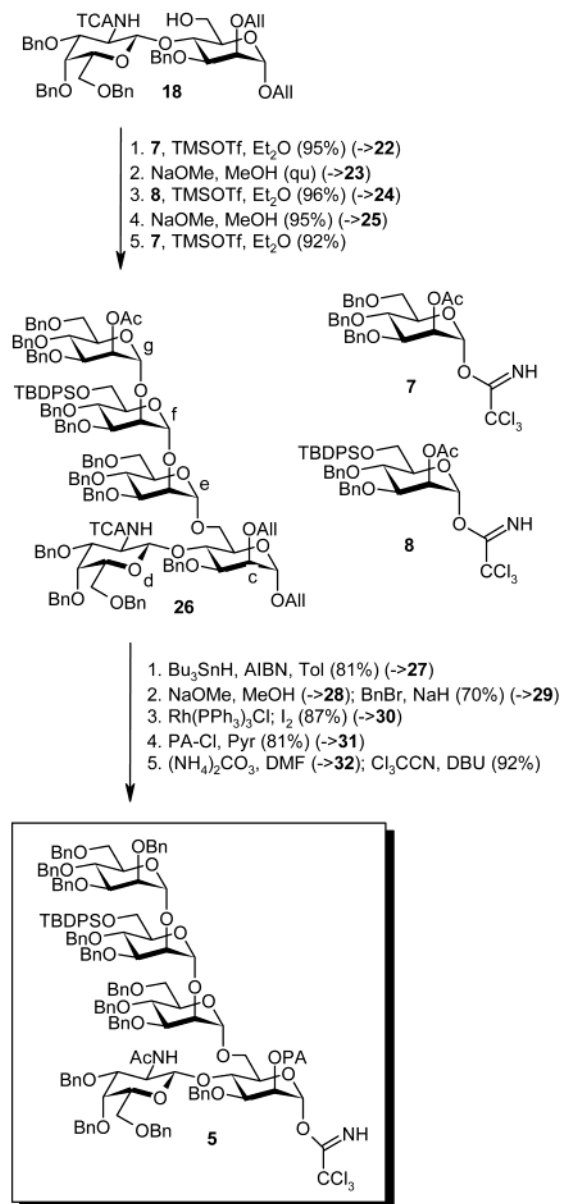
**SCHEME 5. Preparation of Pentasaccharide Trichloroacetimidate 5**

(→**19**) and the primary hydroxy function was selectively protected by formation of the monochloroacetyl ester (→**20**). Glycosylation as described above (→**21**) and subsequent removal of the ester function by treatment with methylamine led to disaccharide **18** in 58% overall yield compared to 36% overall yield of the former pathway. Access to 3,6-branched GPI anchors is easily possible by using a mannose **c** building block similar to **13** having a *p*-methoxybenyl group at *O*-3 and a 4,6-*O*-benzylidene acetal protecting group.

Starting from disaccharide acceptor **18**, the pentasaccharide backbone was built up in a very straightforward manner (see Scheme 5):  $\alpha$ -selective glycosylation of **18** with mannosyl trichloroacetimidate **7** as donor (→**22**), deprotection of the 2-*O*-acetyl function (→**23**), and subsequent glycosylation with mannosyl donor **8** led to tetrasaccharide **24**. Again, deprotection of the 2-*O*-acetyl group (→**25**) and  $\alpha$ -mannosylation with trichloroacetimidate **7** finally led to pentasaccharide **26**. Instead of using

mannosyl trichloroacetimidate **7** in the final glycosylation reaction, other carbohydrate building blocks could be used, thus giving access to structurally different GPI anchors. All  $\alpha$ -mannosylation reactions were completely stereoselective and very high yielding due to the anchimeric assistance of the 2-*O*-acetyl group of the donor building blocks. Full structural assignment of **26** could be performed by a combination of <sup>1</sup>H, <sup>13</sup>C, HMQC, DQF-COSY, and ROESY spectroscopy (see Table 1). The determination of the anomeric configuration of the mannosyl units was performed according to Bock and Petersen.<sup>18</sup> <sup>1</sup>J<sub>C,H</sub> coupling constants (obtained from proton uncoupled HMQC) greater than 170 Hz refer to  $\alpha$ -linkages (e.g., in pentasaccharide **26**: <sup>1</sup>J<sub>C,H-1c</sub> = 170.7 Hz, <sup>1</sup>J<sub>C,H-1e</sub> = 173.2 Hz, <sup>1</sup>J<sub>C,H-1f</sub> = 174.5 Hz, <sup>1</sup>J<sub>C,H-1g</sub> = 172.1 Hz) while the  $\beta$ -galactosidic linkage has a <sup>1</sup>J<sub>C,H-1c</sub> value of 164.1 Hz.

Reduction of the *N*-trichloroacetyl group to the *N*-acetyl group (→**27**) was performed under neutral reaction conditions as developed by Jacquinet et al.<sup>19</sup> Deacetylation of the terminal 2-*O*-acetyl group (→**28**) and benzylation of the free hydroxy functions gave benzylated pentasaccharide **29**. In this three-step sequence it is important to transform the trichloroacetyl group prior to *O*-benzylation as otherwise also *N*-benzylation occurs. Transformation of the 1,2-di-*O*-allyl function in compound **29** to 2-*O*-phenoxyacetyl-protected trichloroacetimidate **5** was performed similar to a protocol used in an earlier GPI total synthesis of our group:<sup>9</sup> deprotection of the allyl protecting groups via isomerization with Wilkinson's catalyst and subsequent cleavage of the enol ethers with iodine gave pentasaccharide **30**, which was diacetylated with phenoxyacetyl (PA) chloride to give compound **31**. Selective removal of the anomeric phenoxyacetyl group (→**32**) by treatment with (NH<sub>4</sub>)<sub>2</sub>CO<sub>3</sub> in DMF at 50 °C for 2 days and trichloroacetimidate formation under standard conditions afforded pentasaccharide trichloroacetimidate **5** in very good overall yield.

**Synthesis of Building Block 6.** To allow for the introduction of a peptide moiety at residue **f**, the amino function of the pseudodisaccharide building block requires liberation and *N*-Boc-protection. Therefore, known pseudodisaccharide **33**<sup>13</sup> was transformed to **6** in 5 steps in good overall yield (see Scheme 6).

In a first sequence of reactions, protection of the free hydroxy function as phenoxyacetyl ester (→**34**), removal of the *p*-methoxybenzyl function with ceric(IV) ammonium nitrate (→**35**), and benzylation with benzoyl cyanide/triethylamine in dichloromethane led to fully protected pseudodisaccharide **36**. The benzoyl ester was chosen as the protecting group for the 1-position of the inositol moiety as it can be quantitatively cleaved without monitoring the cleavage reaction. This seemed to be important as very small changes in polarity of the totally assembled molecule at later stages complicated monitoring of the reaction products and purification in the synthesis. Subsequent removal of the phenoxyacetyl protecting group under mild basic conditions (→**37**), reduction of the azido function (→**38**), and subsequent selective *N*-Boc protection of the free amino group af-

(18) Bock, K.; Petersen, C. *J. Chem. Soc., Perkin Trans. 2* **1974**, 293–297.

(19) Blattner, G.; Beau, J.-M.; Jacquinet, J.-C. *Carbohydr. Res.* **1994**, *260*, 189–202.

**TABLE 1. Correlation Table of Compound 26 (<sup>13</sup>C and <sup>1</sup>H Chemical Shifts at 150.9 and 600 MHz, Respectively)**

position	1	2	3	4	5	6
c	97.3/4.71	74.8/3.68	78.0/3.85	74.0/4.01	70.1/3.68	66.3/3.77 + 3.57
d	99.2/4.97	55.9/3.93	77.4/3.98	72.0/3.75	73.3/3.50	68.2/3.51 + 3.30
e	98.3/4.83	72.7/4.09	80.4/3.87	74.8/3.71	72.1/3.78	69.5/3.62
f	99.9/5.35	75.2/4.08	79.5/3.94	74.1/4.14	73.1/3.73	62.9/4.03 + 3.87
g	99.8/5.07	68.7/5.57	78.6/3.99	74.0/3.90	71.8/3.86	68.5/3.58 + 3.47

**TABLE 2. Correlation Table of Compound 39 (<sup>13</sup>C and <sup>1</sup>H Chemical Shifts at 150.9 and 600 MHz, Respectively)**

position	1	2	3	4	5	6
a	75.1/5.05	74.1/4.21	80.8/3.61	81.9/4.16	79.7/3.49	75.1/4.45
b	98.6/5.33	54.5/3.92	81.5/3.48	73.3/3.83	70.6/3.99	68.6/3.30
c	98.1/5.29	70.2/5.48	75.4/3.75	72.9/4.01	70.8/3.58	66.4/3.80 + 3.16
d	100.8/4.65	52.4/4.26	81.5/3.48	71.9/3.49	73.5/3.52	68.9/3.48 + 3.30
e	99.3/4.55	72.7/4.07	80.1/3.80	75.4/3.42	72.5/3.70	70.9/3.63 + 3.49
f	100.2/5.28	74.4/4.10	/3.88	74.3/4.13	73.1/3.65	62.8/4.01 + 3.82
g	99.6/5.22	74.7/3.86	/3.88	74.7/4.00	72.1/3.81	68.9/3.56 + 3.48

**TABLE 3. Correlation Table of Compound 1c (<sup>13</sup>C and <sup>1</sup>H Chemical Shifts at 150.9 and 600 MHz, Respectively)**

position	1	2	3	4	5	6
a	75.3/4.07	71.1/4.12	70.0/3.49	71.8/3.62	72.2/3.34	76.9/3.83
b	94.7/5.54	53.3/3.30	69.7/4.02	75.8/3.68	70.2/4.11	59.7/3.78 + 3.74
c	98.9/5.35	73.6/4.43	67.6/3.96	76.9/3.79	70.8/3.79	66.3/3.84 + 3.67
d	101.2/4.43	52.1/3.85	70.0/3.70	67.2/3.86	74.9/3.66	66.3/3.84 - 3.67
e	98.3/5.03	78.6/3.92	89.6/3.88	66.5/3.61	72.9/3.63	66.3/3.84 - 3.67
f	100.3/5.19	77.7/4.05	89.4/3.90	65.9/3.71	71.7/3.80	64.2/4.04
g	101.6/4.98	69.6/3.99	69.9/3.76	66.3/3.56	72.8/3.69	66.3/3.84 - 3.67

forded pseudodisaccharide **6** in good overall yield. Thus, the syntheses of all required building blocks could be very successfully performed.

**Construction of Target Molecules 1a–1c (see Scheme 7).** To construct the carbohydrate backbone of the GPI anchor, glycosyl acceptor **6** was treated with pentasaccharide trichloroacetimidate **5** under standard glycosylation conditions, i.e., with TMSOTf as catalyst in dry diethyl ether as solvent at room temperature. The desired  $\alpha$ -connected pseudoheptasaccharide **39** was selectively obtained in excellent yield. The configuration of all glycosidic linkages could be assigned by the  $^1J_{C,H}$  coupling constants:  $\alpha$ -linkages for  $^1J_{C,H-1b} = 174.4$  Hz,  $^1J_{C,H-1c} = 176.2$  Hz,  $^1J_{C,H-1e} = 173.4$  Hz,  $^1J_{C,H-1f} = 174.4$  Hz,  $^1J_{C,H-1g} = 170.7$  Hz and the  $\beta$ -galactosidic linkage with  $^1J_{C,H-1d} = 160.5$  Hz (for correlation data of all other  $^{13}C/^1H$  pairs see Table 2).

Removal of the silyl protecting group with acetic acid buffered TBAF at 40 °C in THF over several days gave intermediate **40**. Phosphorylation with benzyloxycarbonyl protected ethanolamine phosphoramidite **2**<sup>10</sup> and immediate removal of the phenoxyacetyl group while eliminating the cyanoethyl group on the phosphate group led to monophosphorylated compound **41** with the 2c-hydroxy function already deprotected. Due to the choice of the cyanoethyl protecting group on the phosphate residue only one diastereomer of compound **41** was obtained. Subsequent phosphorylation at the O-2c-position with *N*-Boc-protected phosphoramidite building block **3**<sup>20</sup> ( $\rightarrow$ **42**) and deprotection of the benzoyl group on the inositol moiety with sodium methanolate in methanol overnight gave advanced intermediate **43** in excellent yield. To ensure the integrity of the backbone, compound **43** was

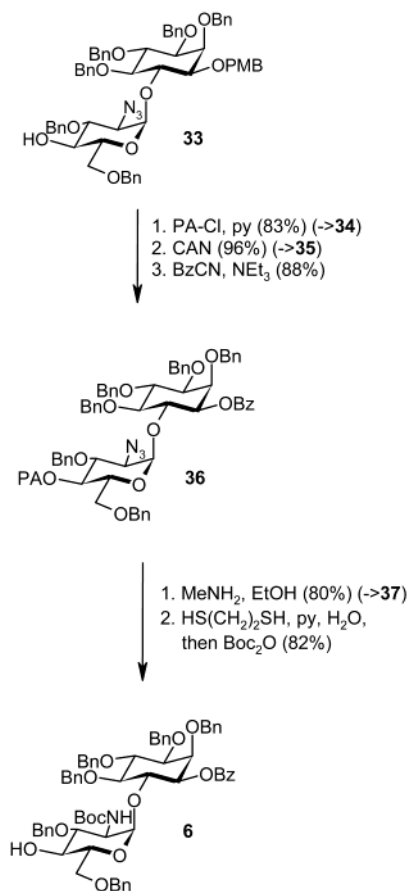
**SCHEME 6. Preparation of Building Block 6**

phosphorylated with dibenzyl *N,N*-diisopropylphosphoramidite to give fully phosphorylated compound **44**. Deprotection by hydrogenation ( $\rightarrow$ **45**) and subsequent treat-

(20) Watanabe, Y.; Sofue, S.; Ozaki, S.; Hirata, M. *J. Chem. Soc., Chem. Commun.* **1996**, 15, 1815–1816.

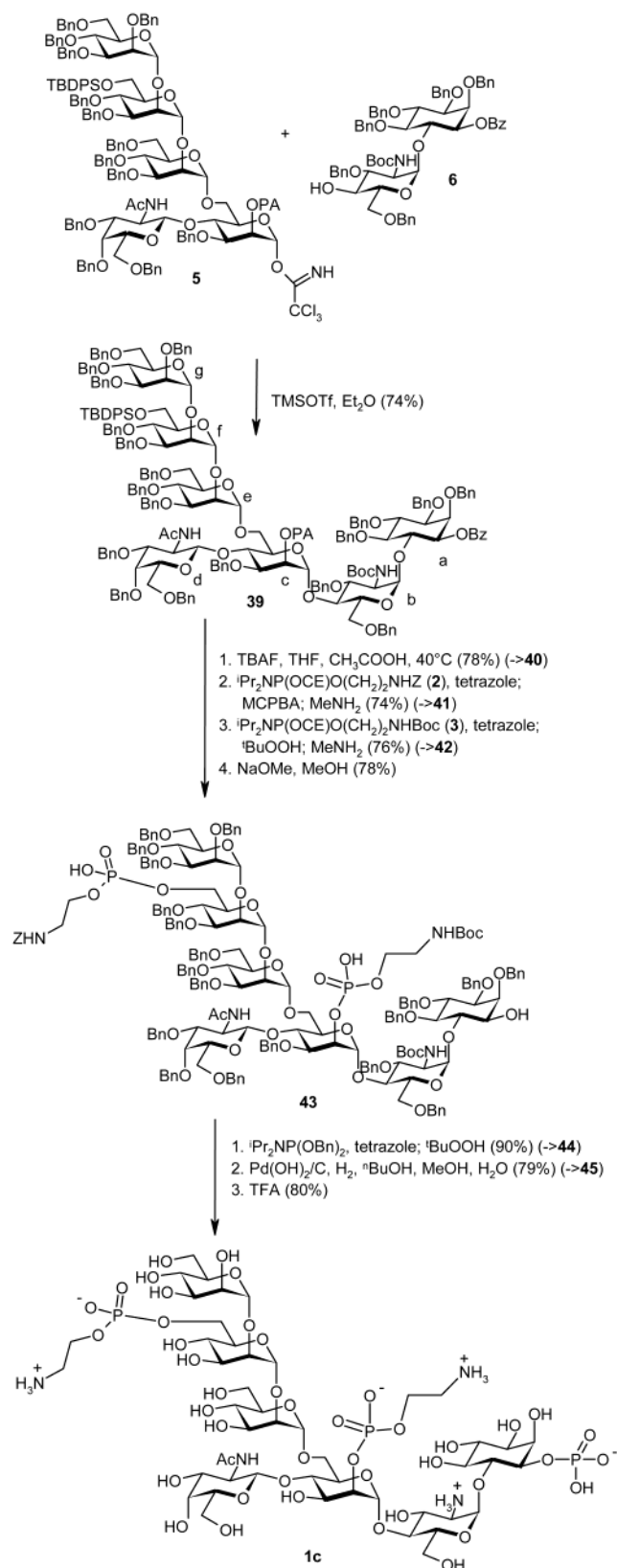
**SCHEME 7. Preparation of the Carbohydrate Backbone**

ment with TFA afforded the fully phosphorylated water soluble GPI anchor of *rat brain* Thy-1 **1c**.

Full structural assignment could be obtained by means of one- and two-dimensional NMR techniques (see Table

3). The anomeric configurations could be proven by <sup>1</sup>J<sub>C,H</sub> coupling constants (<sup>1</sup>J<sub>C,H-1b</sub> = 178.1 Hz, <sup>1</sup>J<sub>C,H-1c</sub> = 175.7 Hz, <sup>1</sup>J<sub>C,H-1e</sub> = 173.3 Hz, <sup>1</sup>J<sub>C,H-1f</sub> = 174.5 Hz, <sup>1</sup>J<sub>C,H-1g</sub> = 172.1 Hz, all of them being α-linked; <sup>1</sup>J<sub>C,H-1d</sub> = 162.6 Hz, β-linked). The phosphorus signals, corresponding to the three phosphate esters, were obtained at δ = -2.36, -2.61, and -3.15 ppm.

To arrive at the final goal, i.e., the lipidated GPI anchor, advanced intermediate **44** was lipidated by using phosphoramidite building block **4** under standard conditions with tetrazole activation in dichloromethane as solvent (see Scheme 8). Oxidation with *tert*-butyl hydroperoxide, instead of *m*-chloroperbenzoic acid as in the previous phosphorylations, and elimination of the cyanoethyl group by treatment with dimethylamine gave the fully protected GPI anchor **46** of *rat brain* Thy-1 and of *scrapie* prion protein, respectively. Removal of the Boc-protecting groups (->**47**) by treatment with TFA and Et<sub>3</sub>SnH as scavenger followed by hydrogenation with Pearlman's catalyst afforded the desired fully deprotected GPI-anchor **1a**. To allow for the introduction of a peptide residue at the GPI anchor, selectively deprotected GPI-anchor **1b** was synthesized by hydrogenation of intermediate **45** with Pearlman's catalyst.

The comparison of the anomeric region of the <sup>1</sup>H NMR of compounds **1c** and **1a** with that of the naturally occurring GPI anchor glycan, which was obtained from natural sources by Ferguson et al.,<sup>1,2</sup> showed great similarities (see Figure 1); the compound isolated from natural sources was not lipidated and contained an impurity. The pattern of the anomeric proton signals in the <sup>1</sup>H NMR spectrum of the synthetic, water soluble, GPI anchor glycan **1c** (bottom left side in Figure 1) is in good accordance with that of the isolated GPI anchor glycan (top in Table 1). Even the lipidated GPI anchor **1a** has a <sup>1</sup>H spectroscopic pattern in the anomeric region very similar to that of the water-soluble GPI (bottom right side in Figure 1). The downfield shift of the **1c** proton in lipidated compound **1a** can be easily explained by the short distance between this proton and the lipid anchor.

**Conclusion**

In summary, a highly variable concept for the synthesis of branched GPI anchors could be established. It is based on versatile building blocks which are readily accessible and permitted high regio- and stereoselectivity in all reaction steps. The efficiency of this concept could be shown by the synthesis of the 4,6-branched GPI anchor of *rat brain* Thy-1 and *scrapie* prion protein, which was synthesized in the water-soluble form as well as in the lipidated form. The synthetic concept further allows the attachment of a peptide moiety or different biological markers to the GPI anchor. Therefore, in principle the synthesis of a large number of branched or linear GPI anchors or derivatives of them can be easily performed by using this synthetic strategy.

**Experimental Section**

Solvents were purified in the usual way; the boiling range of petroleum ether was 35–65 °C. Melting points are uncorrected. <sup>1</sup>H NMR were recorded at 250 and 600 MHz with an

## SCHEME 8. Preparation of the GPI Anchor of Rat Brain Thy-1

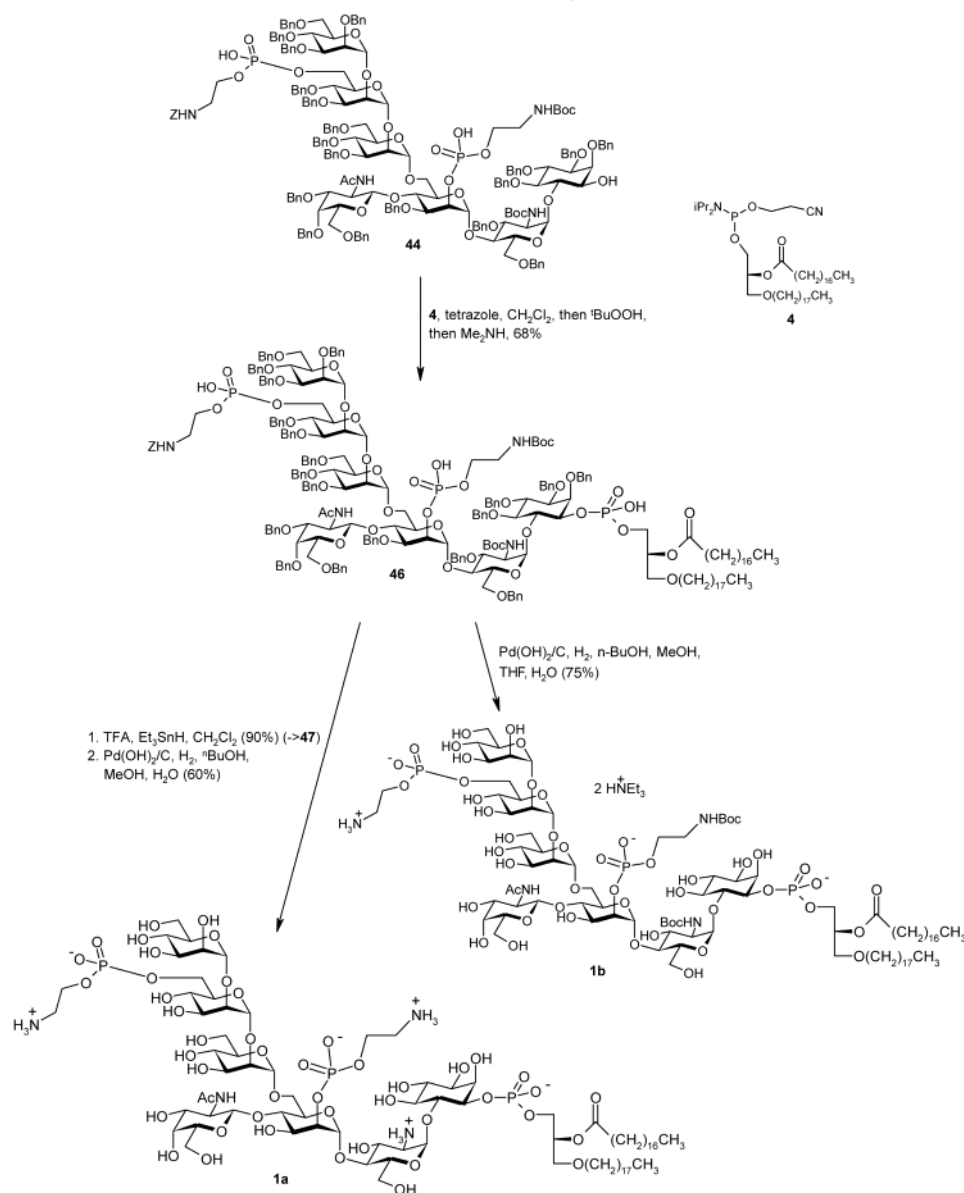

internal standard of tetramethylsilane (TMS). FAB MS were recorded with the NBOH (= 3-nitrobenzyl alcohol) matrix.

**3-*O*-Benzyl-1-*O*-octadecyl-*sn*-glycerol (10), 3-*O*-Benzyl-2-*O*-octadecanoyl-1-*O*-octadecyl-*sn*-glycerol (11), and 2-*O*-Octadecanoyl-1-*O*-octadecyl-*sn*-glycerol (12).** A mixture of 3-*O*-benzyl-*sn*-glycerol (6.65 g, 36.74 mmol)<sup>16</sup> and dibutyltin oxide (9.60 g, 38.58 mmol) in 250 mL of dry toluene was stirred under reflux with azeotropic removal of water for 2 h. The mixture was then cooled and concentrated to dryness to give a white solid, which was mixed with petroleum ether, stirred for 15 min, and filtered to furnish 14.7 g of the dibutylstannylene-acetal. A 7.35-g sample of this compound, 1-bromooctadecane (6.2 g, 18.63 mmol), and tetrabutylammonium iodide (TBAI) (6.57 g, 17.8 mmol) were stirred in 200 mL of dry DMF at 140 °C for 3.5 h and then concentrated. The residue was dissolved in ethyl acetate, and the organic solution was washed with brine and water, dried ( $\text{MgSO}_4$ ), and concentrated to give an oil ( $\rightarrow$ 10). TLC [petroleum ether/ethyl acetate (5:1)]  $R_f$  0.35. A mixture of this material, triethylamine (6.3 mL, 41.40 mmol), and stearoyl chloride (13.8 mL, 41.40 mmol) was stirred in 30 mL of dry  $\text{CH}_2\text{Cl}_2$  at room temperature overnight then diluted with ethyl acetate, washed with brine and water, dried ( $\text{MgSO}_4$ ), and concentrated ( $\rightarrow$ 11). The

residue was dissolved in 50 mL of THF/MeOH 1:1 and some Pd/C was added. This mixture was stirred under  $\text{H}_2$  for 1 h and concentrated. Flash chromatography (petroleum ether/ethyl acetate 9:1  $\rightarrow$  7:1) afforded compound 12 (3.7 g, 6.05 mmol, 33%) as a white solid. TLC [petroleum ether/ethyl acetate (9:1)]  $R_f$  0.25;  $[\alpha]_D -2.5$  ( $c = 1.0$ ,  $\text{CDCl}_3$ );  $^1\text{H NMR}$  (250 MHz,  $\text{CDCl}_3$ )  $\delta$  0.88 (m, 6H, 2 Me), 1.18–1.40 (m, 58H,  $\text{CH}_2$ ), 1.53–1.66 (m, 4H,  $\text{CH}_2$ ), 2.21 (m, 1H, OH), 2.36 (m, 2H,  $\text{CH}_2\text{-COO}$ ), 3.41–3.49 (m, 2H,  $\text{CH}_2\text{C}(\text{H}_2)\text{O}$ ), 3.56–3.68 (m, 2H, 1/1'-H), 3.81 (m, 2H, 3/3'-H), 5.00 (m, 1H, 2-H). Anal. Calcd for  $\text{C}_{39}\text{H}_{78}\text{O}_4$  (611.17): C 76.66, H 12.87. Found: C 76.59, H 13.08.

**(2-Cyanoethoxy)(2-*O*-octadecanoyl-1-*O*-octadecyl-*sn*-glyceryl)(diisopropylamino)phosphine (4).** Compound 12 (500 mg, 820  $\mu\text{mol}$ ), 2-cyanoethoxybis(diisopropylamino)phosphine (285  $\mu\text{L}$ , 902  $\mu\text{mol}$ ) and tetrazole (28 mg, 180  $\mu\text{mol}$ ) were dried in a vacuum for 2 h. After addition of 5.0 mL of dry  $\text{CH}_2\text{Cl}_2$  the solution was stirred under argon at room temperature for 90 min. The solution was diluted with  $\text{CH}_2\text{-Cl}_2$ , washed with saturated  $\text{NaHCO}_3$  solution, and dried ( $\text{MgSO}_4$ ) and the solvent was removed. Flash chromatography (petroleum ether/ethyl acetate 30:1) afforded compound 4 (600 mg, 705  $\mu\text{mol}$ , 86%) as a colorless wax. TLC [petroleum ether/ethyl acetate (18:2)]  $R_f$  0.80;  $^1\text{H NMR}$  (250 MHz,  $\text{CDCl}_3$ )  $\delta$  0.89

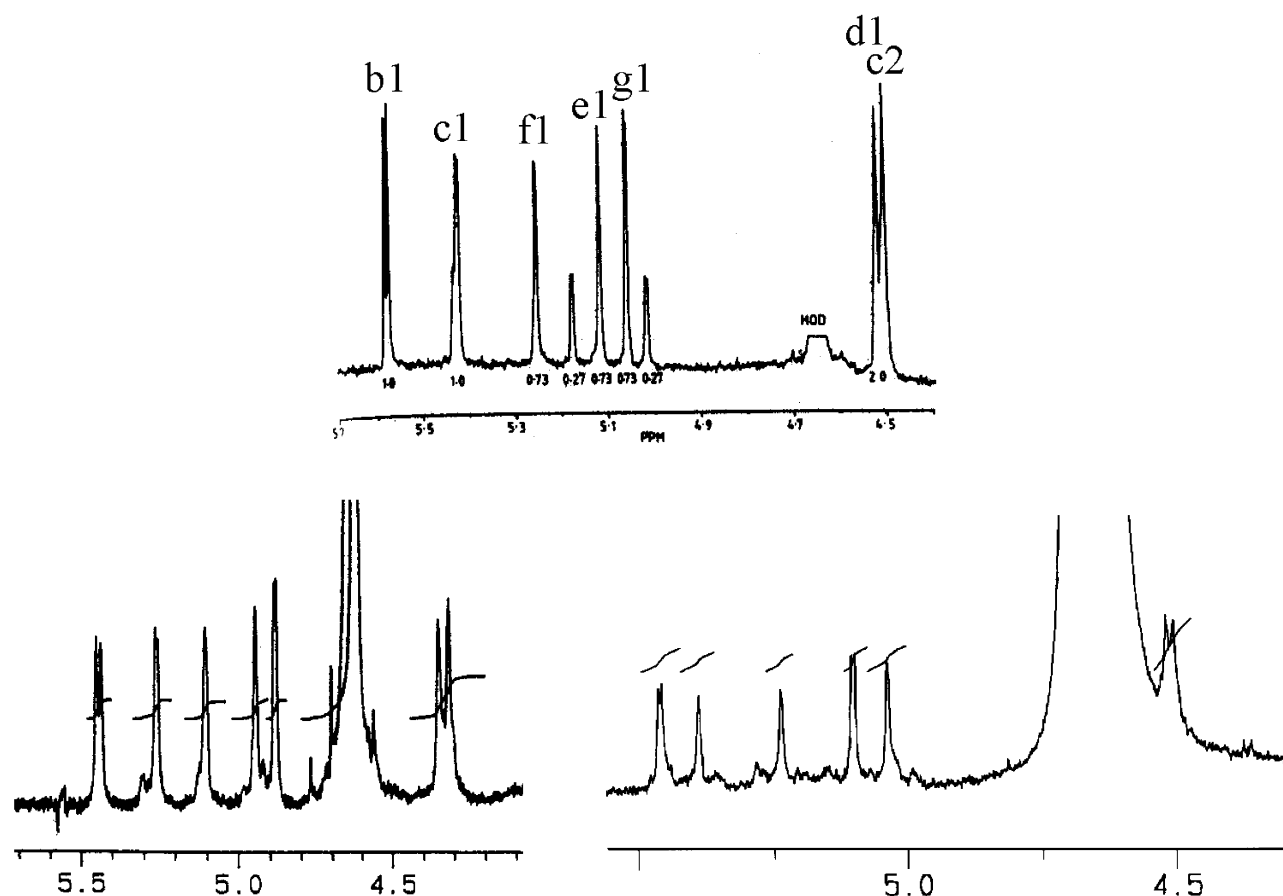

**FIGURE 1.**  $^1\text{H}$  spectra of the anomeric region of the *rat brain* Thy-1 GPI (top, naturally occurring compound; bottom left, synthetic GPI anchor glycan **1c**; bottom right, synthetic GPI anchor **1a**; spectra of the synthetic GPI anchors were recorded at 293 K in  $\text{D}_2\text{O}$  and  $\text{D}_2\text{O}/d_4\text{-MeOH}$ , respectively).

(t, 6H, 2Me), 1.18 (d, 6H, Me), 1.20 (d, 6H, Me), 1.23–1.40 (m, 58H,  $\text{CH}_2$ ), 1.51–1.64 (m, 4H,  $\text{CH}_2$ ), 2.31 (t, 2H,  $\text{CH}_2\text{COO}$ ), 3.37–3.50 (m, 2H,  $\text{CH}_2\text{O}$ ), 3.58 (d, 2H, 1'-H), 3.61–3.84 (m, 4H,  $\text{Me}_2\text{CH}$ ), 4.61–4.76 (m, 2H,  $\text{CH}_2\text{Ph}$ ), 5.12–5.16 (m, 1H, 2-H), 7.24–7.37 (m, 5H, Ph).

**Allyl 2-O-Allyl-3-O-benzyl-4,6-O-(4-methoxybenzylidene)- $\alpha$ -D-mannopyranoside (14).** Compound **13**<sup>13</sup> (15 g, 35 mmol) was dissolved with allyl bromide (3.9 mL, 4.6 mmol) in 160 mL of DMF and sodium hydride (1.09 g, 4.5 mmol) was added in portions. After 1 h some methanol was added and the solvent was removed. Flash chromatography (petroleum ether/ethyl acetate 4:1) of the residue afforded compound **14** (15.6 g, 33 mmol, 95%) as a syrup. TLC [petroleum ether/ethyl acetate (3:1)]  $R_f$  0.60;  $[\alpha]_D^{25} +38$  ( $c$  2.5,  $\text{CDCl}_3$ );  $^1\text{H}$  NMR (250 MHz,  $\text{CDCl}_3$ )  $\delta$  3.82 (s, 3H, OMe), 3.76–4.18 (m, 5H, 4-H, allyl, 6',5,2-H), 4.12–4.35 (m, 5H, 3  $\times$  allyl, 6,3-H), 4.69 (d,  $J_{\text{H,H}} = 12.2$  Hz, 1H,  $\text{CH}_2\text{Ph}$ ), 4.85 (d,  $J_{\text{H,H}} = 1.5$  Hz,  $^1J_{\text{CH}} = 171.8$  Hz, 1H, 1-H), 4.86 (d,  $J_{\text{H,H}} = 12.2$  Hz, 1H,  $\text{CH}_2\text{Ph}$ ), 5.16–5.34 (m, 4H, allyl), 5.59 (s, 1H, benzylidene), 5.81–6.01 (m, 2H, allyl), 6.85–6.91 (m, 2H, PMB), 7.26–7.44 (m, 8H); HMQC data ( $^{13}\text{C}$  (150.9 MHz)/ $^1\text{H}$  (600 MHz)) 98.7/4.85 (1c), 76.5/3.8 (2c), 79.0/4.17 (3c), 76.2/3.96 (4c), 64.2/3.81 (5c), 68.7/4.22 + 3.85 (6c). Anal. Calcd for  $\text{C}_{27}\text{H}_{32}\text{O}_7$  (468.59): C 69.20, H 6.90. Found: C 69.34, H 6.94.

**Allyl 2-O-Allyl-3-O-benzyl-6-O-(4-methoxybenzyl)- $\alpha$ -D-mannopyranoside (15).** Compound **14** (5.4 g, 11.5 mmol) and sodium cyanoborohydride (3.62 g, 57.6 mmol) were dissolved with some MS 4 Å in 80 mL of dry DMF and cooled to  $-20$  °C. After addition of 7.8 mL of TFA in 40 mL of dry DMF the mixture was stirred at  $-20$  °C under argon for 3 days. After neutralization with triethylamine the reaction mixture was dissolved with ethyl acetate and washed with saturated

$\text{NaHCO}_3$  solution and water and dried ( $\text{MgSO}_4$ ). Removal of the solvent and flash chromatography (petroleum ether/ethyl acetate 3:1) afforded compound **15** (3.73 g, 7.91 mmol, 68%) and allyl 2-O-allyl-3-O-benzyl-4-O-(4-methoxybenzyl)- $\alpha$ -D-mannopyranoside (1.1 g, 2.25 mmol, 20%), both as colorless foams. **15**: TLC [petroleum ether/ethyl acetate (2:1)]  $R_f$  0.50;  $[\alpha]_D^{25} +11.0$  ( $c$  1.6,  $\text{CDCl}_3$ );  $^1\text{H}$  NMR (250 MHz,  $\text{CDCl}_3$ )  $\delta$  2.52 (d,  $J_{\text{OH}} = 1.9$  Hz, 1H, 4-OH), 3.68–3.81 (m, 5H), 3.72 (s, 3H, OMe), 3.93–4.03 (m, 2H, allyl), 4.10–4.25 (m, 3H, allyl), 4.50 (d,  $J_{\text{H,H}} = 11.3$  Hz, 1H, PMB), 4.55 (d,  $J_{\text{H,H}} = 11.3$  Hz, 1H, PMB), 4.60 (d,  $J_{\text{H,H}} = 12.2$  Hz, 1H,  $\text{CH}_2\text{Ph}$ ), 4.72 (d,  $J_{\text{H,H}} = 12.2$  Hz, 1H,  $\text{CH}_2\text{Ph}$ ), 4.90 (br s, 1H, 1-H), 5.15–5.31 (m, 4H, allyl), 5.89 (m, 2H, allyl), 6.82–6.88 (m, 2H, PMB), 7.22–7.40 (m, 7H, Ph); HMQC data ( $^{13}\text{C}$  (150.9 MHz)/ $^1\text{H}$  (600 MHz)) = 97.4/4.90 (1c), 74.1/3.74 (2c), 79.5/3.73 (3c), 71.4/3.72 (4c), 70.1/3.71 (5c), 72.1/4.13 (6c). Anal. Calcd for  $\text{C}_{27}\text{H}_{34}\text{O}_7$  (470.61): C 68.90, H 7.30. Found: C 68.81, H 7.33. Other isomer: TLC [petroleum ether/ethyl acetate (3:1)]  $R_f$  0.20;  $[\alpha]_D^{25} +22.8$  ( $c$  1.9,  $\text{CDCl}_3$ );  $^1\text{H}$  NMR (250 MHz,  $\text{CDCl}_3$ )  $\delta$  1.99 (t,  $J_{\text{OH}} = 6.6$  Hz, 1H, 6-OH), 3.60–3.98 (m, 8H), 3.79 (s, 3H, OMe), 4.10–4.28 (m, 3H), 4.56 (d,  $J_{\text{H,H}} = 12.0$  Hz, 1H), 4.72 (br s, 2H,  $\text{CH}_2\text{Ph}$ ), 4.82–4.88 (m, 2H, 1-H,  $\text{CH}_2\text{Ph}$ ), 5.15–5.33 (m, 4H, allyl), 6.80–6.88 (m, 2H, PMB), 7.18–7.41 (m, 7H, Ph). Anal. Calcd for  $\text{C}_{27}\text{H}_{34}\text{O}_7$  (470.61): C 68.90, H 7.30. Found: C 68.56, H 7.39.

**Allyl (3,4,6-Tri-O-benzyl-2-deoxy-2-trichloroacetamido- $\beta$ -D-galactopyranosyl)-(1 $\rightarrow$ 4)-2-O-allyl-3-O-benzyl-6-O-(4-methoxybenzyl)- $\alpha$ -D-mannopyranoside (17).** Acceptor **14** (2.38 g, 5.1 mmol) and trichloroacetimidate **16**<sup>13</sup> (3.93 g, 5.3 mmol) were dissolved in 45 mL of dry toluene under argon and cooled to  $-60$  °C.  $\text{BF}_3 \cdot \text{OEt}_2$  (500  $\mu\text{L}$ ) was added 5 times every 30 min. After 1 h the temperature was raised to  $-40$  °C. Neutralization with triethylamine, removal of the solvent,



and flash chromatography (petroleum ether/ethyl acetate 6:1 → 5:1 → 2:1) afforded disaccharide **17** (3.9 g, 3.72 mmol, 73%) as a colorless syrup. For TLC: One drop of the reaction mixture has to be rapidly dissolved in one drop of triethylamine. TLC [petroleum ether/ethyl acetate (3:1)]  $R_f$  0.45;  $[\alpha]_D^{25} +18$  (c 1.1,  $\text{CDCl}_3$ );  $^1\text{H NMR}$  (250 MHz,  $\text{CDCl}_3$ )  $\delta$  3.36–3.49 (m, 2H), 3.50–3.60 (m, 1H), 3.62–3.78 (m, 7H), 3.80–4.00 (m, 5H), 4.02–4.20 (m, 4H), 4.20–4.64 (m, 8H), 4.76–4.88 (m, 4H), 5.06–5.28 (m, 4H), 5.72–5.95 (m, 2H, allyl), 6.66 (d,  $J_{\text{NH}} = 10.6$  Hz, 1H, NH), 6.80–6.85 (m, 2H, PMB), 7.18–7.35 (m, 23H, Ph); HMQC data ( $^{13}\text{C}$  (150.9 MHz)/ $^1\text{H}$  (600 MHz)) 97.6/4.85 (1c), 75.3/3.71 (2c), 78.2/3.85 (3c), 74.6/4.10 (4c), 70.9/3.73 (5c), 69.0/3.65 (6c), 99.2/4.81 (1d), 55.9/3.94 (2d), 78.2/3.85 (3d), 72.1/3.94 (4d), 73.4/3.42 (5d), 68.2/3.55 + 3.38 (6d). Anal. Calcd for  $\text{C}_{58}\text{H}_{62}\text{O}_{12}\text{NCl}_3$  (1047.54): C 66.50, H 5.98, N 1.34. Found: C 66.46, H 5.94, N 1.16.

**Allyl (3,4,6-Tri-*O*-benzyl-2-deoxy-2-trichloroacetamido- $\beta$ -D-galactopyranosyl)-(1→4)-2-*O*-allyl-3-*O*-benzyl- $\alpha$ -D-mannopyranoside (18).** From **17**: Disaccharide **17** (2.87 g, 2.74 mmol) and ceric(IV) ammonium nitrate (7.47 g, 12.7 mmol) were stirred in 220 mL of  $\text{CH}_3\text{CN}$ /toluene/ $\text{H}_2\text{O}$  50/45/5 at 0 °C for half an hour and at room temperature for 2 h. The reaction mixture was diluted with ethyl acetate, washed with saturated  $\text{NaHCO}_3$  solution, dried over  $\text{Na}_2\text{SO}_4$ , and evaporated. Flash chromatography (petroleum ether/ethyl acetate 3:1 → 2:1) afforded compound **18** (1.91 g, 2.06 mmol, 75%) as colorless foam.

**(b) From 21:** Compound **21** (720 mg, 706  $\mu\text{mol}$ ) was dissolved in 2 mL of dry methanol and 2 mL of dry diethyl ether and 1 mL of  $\text{MeNH}_2$  solution (33% in dry ethanol) was added. The solvent was removed after 15 min and subsequent flash chromatography (petroleum ether/ethyl acetate 1:1) of the residue afforded compound **18** (617 mg, 665  $\mu\text{mol}$ , 88%) as a colorless foam.

TLC [petroleum ether/ethyl acetate (2:1)]  $R_f$  0.11;  $[\alpha]_D^{25} +47$  (c 1.5,  $\text{CDCl}_3$ );  $^1\text{H NMR}$  (250 MHz,  $\text{CDCl}_3$ )  $\delta$  2.04 (br s, 1H, OH), 3.39 (dd,  $J_{5,6} = 5.1$  Hz,  $J_{6,6} = 9.1$  Hz, 1H, 6d-H), 3.68 (m, 3H, 5c, 5d, 6'd-H), 3.72–3.77 (m, 3H, 2c, 6c, 6'c-H), 3.86–4.76 (m, 16H, see table), 4.84–4.90 (m, 2H, 1c-H), 5.04–5.29 (m, 5H,  $\text{CH}_2\text{Ph}$ , 1d-H), 5.71–5.95 (m, 2H, allyl), 6.90 (d,  $J_{\text{NH}} = 7.4$  Hz, 1H, NH), 7.20–7.35 (m, 20H, Ph); HMQC data ( $^{13}\text{C}$  (150.9 MHz)/ $^1\text{H}$  (600 MHz)) 97.7/4.84 (1c), 74.8/3.75 (2c), 78.4/3.88 (3c), 73.2/4.19 (4c), 71.9/3.61 (5c), 62.2/3.76 (6c), 99.0/5.09 (1d), 56.2/3.97 (2d), 77.3/4.14 (3d), 71.9/3.97 (4d), 73.3/3.55 (5d), 68.3/3.55 + 3.39 (6d). Anal. Calcd for  $\text{C}_{48}\text{H}_{54}\text{O}_{11}\text{Cl}_3\text{N}$  (927.38): C 62.61, H 5.88, N 1.51. Found: C 62.08, H 5.91, N 1.25.

**Allyl 2-*O*-Allyl-3-*O*-benzyl- $\alpha$ -D-mannopyranoside (19).** Compound **14** (15.5 g, 33 mmol) and CSA (420 mg, 1.6 mmol) were dissolved in 70 mL of diethyl ether and 70 mL of methanol. After stirring for 1.5 h and removal of the solvent, flash chromatography (petroleum ether/ethyl acetate 1:1 → 2:3) afforded compound **19** (11.5 g, 33 mmol, qu.) as a colorless solid. TLC [petroleum ether/ethyl acetate (1:1)]  $R_f$  0.2;  $[\alpha]_D^{25} +23$  (c 2.0,  $\text{CDCl}_3$ );  $^1\text{H NMR}$  (250 MHz,  $\text{CDCl}_3$ )  $\delta$  2.15 (br s, 1H, OH), 2.43 (br s, 1H, OH), 3.61–3.69 (m, 1H), 3.70–3.86 (m, 4H), 3.88–4.02 (m, 2H), 4.13–4.24 (m, 3H), 4.57 (d,  $J_{\text{H,H}} = 11.6$  Hz, 1H,  $\text{CH}_2\text{Ph}$ ), 4.74 (d,  $J_{\text{H,H}} = 11.6$  Hz, 1H,  $\text{CH}_2\text{Ph}$ ), 4.91 (d,  $J_{1,1} = 1.2$  Hz, 1H, 1c-H), 5.17–5.33 (m, 4H, allyl), 5.83–5.99 (m, 2H, allyl), 7.28–7.39 (m, 5H, Ph). Anal. Calcd for  $\text{C}_{19}\text{H}_{26}\text{O}_6$  (350.45): C 63.20, H 7.58 (+ $1/2\text{H}_2\text{O}$ ). Found: C 63.95, H 7.46.

**Allyl 2-*O*-Allyl-3-*O*-benzyl-6-*O*-monochloroacetyl- $\alpha$ -D-mannopyranoside (20).** Compound **19** (10 g, 28.5 mmol) and imidazole (4.2 g, 62 mmol) were dissolved under argon in 115 mL of dry  $\text{CH}_2\text{Cl}_2$  and monochloroacetyl chloride (2.5 mL, 31 mmol) was added. The solvent was removed after 1 h and flash chromatography (petroleum ether/ethyl acetate 3:1) of the residue afforded compound **20** (9.1 g, 20.4 mmol, 75%) as a colorless syrup. All side products were collected and treated with 1 mL of  $\text{MeNH}_2$  solution (33% in dry ethanol) in 25 mL of  $\text{CH}_2\text{Cl}_2$ . Evaporation of the solvent and flash chromatography (petroleum ether/ethyl acetate 2:1) afforded compound **19**

(2.2 g, 6.3 mmol, 22%). TLC [petroleum ether/ethyl acetate (1:1)]  $R_f$  0.65;  $[\alpha]_D^{25} +10$  (c 1.0,  $\text{CDCl}_3$ );  $^1\text{H NMR}$  (250 MHz,  $\text{CDCl}_3$ )  $\delta$  2.38 (d,  $J_{\text{OH}} = 2.0$  Hz, 1H, OH), 3.70–3.84 (m, 3H), 3.90 (dd,  $J_{2,3} = 2.4$  Hz,  $J_{3,4} = 9.2$  Hz, 1H, 3c-H), 3.93–4.04 (m, 1H), 4.08–4.22 (m, 5H), 4.41–4.48 (m, 2H), 4.55 (d,  $J_{\text{H,H}} = 11.6$  Hz, 1H,  $\text{CH}_2\text{Ph}$ ), 4.72 (d,  $J_{\text{H,H}} = 11.6$  Hz, 1H,  $\text{CH}_2\text{Ph}$ ), 4.90 (d,  $J_{1,2} = 1.1$  Hz, 1H, 1c-H), 5.13–5.32 (m, 4H, allyl), 5.82–5.97 (m, 2H, allyl), 7.31–7.38 (m, 5H). Anal. Calcd for  $\text{C}_{21}\text{H}_{27}\text{O}_7\text{Cl}$  (426.93): C 59.08, H 6.39. Found: C 59.19, H 6.35.

**Allyl (3,4,6-Tri-*O*-benzyl-2-deoxy-2-trichloroacetamido- $\beta$ -D-galactopyranosyl)-(1→4)-2-*O*-allyl-3-*O*-benzyl-6-*O*-monochloroacetyl- $\alpha$ -D-mannopyranoside (21).** Compound **20** (5.0 g, 11.3 mmol) and trichloroacetimidate **16** (9.6 g, 13.0 mmol) were dissolved in 140 mL of dry toluene under argon and cooled to –40 °C.  $\text{BF}_3\cdot\text{OEt}_2$  solution (6 mL, 0.2 N solution in dry toluene) was added 5 times every 30 min. After 1 h the temperature was raised to –30 °C. Neutralization with triethylamine, removal of the solvent, and flash chromatography (petroleum ether/ethyl acetate 6:1 → 5:1 → 2:1) of the remaining residue afforded compound **21** (9.8 g, 9.6 mmol, 85%) as a colorless solid. TLC [petroleum ether/ethyl acetate (3:1)]  $R_f$  0.39;  $[\alpha]_D^{25} +21$  (c 1.7,  $\text{CDCl}_3$ );  $^1\text{H NMR}$  (250 MHz,  $\text{CDCl}_3$ )  $\delta$  3.32–3.39 (m, 1H), 3.48–3.62 (m, 2H), 3.70–4.75 (m, 22H), 4.81–4.92 (m, 2H), 5.20–5.32 (m, 5H), 5.70–5.98 (m, 2H, allyl), 6.96 (d,  $J_{\text{NH}} = 6.7$  Hz, 1H, NH), 7.17–7.38 (m, 20H, Ph). Anal. Calcd for  $\text{C}_{50}\text{H}_{55}\text{O}_{13}\text{Cl}_4\text{N}$  (1019.86): C 58.88, H 5.45, N 1.37. Found: C 58.52, H 5.64, N 1.20.

**Allyl (2-*O*-Acetyl-3,4,6-tri-*O*-benzyl- $\alpha$ -D-mannopyranosyl)-(1→6)-[(3,4,6-tri-*O*-benzyl-2-deoxy-2-trichloroacetamido- $\beta$ -D-galactopyranosyl)-(1→4)]-2-*O*-allyl-3-*O*-benzyl- $\alpha$ -D-mannopyranoside (22).** Compound **18** (2.78 g, 3.0 mmol) and trichloroacetimidate **7** (2.29 g, 3.6 mmol) [120] were dissolved in 31 mL of dry diethyl ether and 4.6 mL of dry  $\text{CH}_2\text{Cl}_2$  under argon and cooled to –10 °C ( $\text{NaCl}/\text{ice}$ ). After addition of a 0.1 N TMSOTf solution (1.5 mL), stirring at –10 °C for 10 min, and neutralization with triethylamine, the solvent was removed. Flash chromatography (petroleum ether/ethyl acetate 7:2) of the residue afforded compound **22** (4.0 g, 2.9 mmol, 95%) as a colorless foam. TLC [petroleum ether/ethyl acetate (2:1)]  $R_f$  0.52;  $[\alpha]_D^{25} +26$  (c 1.0,  $\text{CDCl}_3$ );  $^1\text{H NMR}$  (250 MHz,  $\text{CDCl}_3$ )  $\delta$  2.12 (s, 3H, OAc), 3.05–3.16 (m, 2H), 3.32 (m, 1H), 3.47–4.14 (m, 22H), 4.17–4.55 (m, 8H), 4.61–4.93 (m, 7H, 1e-H, 1c-H), 5.02–5.28 (m, 5H, 1d-H), 5.34 (dd,  $J_{1,2} = 1.9$  Hz,  $J_{2,3} = 5.0$  Hz, 1H, 2e-H), 5.71–5.89 (m, 2H, allyl), 7.04 (d,  $J_{\text{NH}} = 7.04$  Hz, 1H, NH), 7.10–7.36 (m, 35H, Ph); HMQC data ( $^{13}\text{C}$  (150.9 MHz)/ $^1\text{H}$  (600 MHz)) 97.2/4.83 (1c), 74.7/3.74 (2c), 78.3/3.92 (3c), 74.1/4.03 (4c), 70.1/3.79 (5c), 66.5/3.82 (6c), 99.0/5.12 (1d), 56.3/3.92 (2d), 77.2/4.10 (3d), 72.0/3.87 (4d), 73.3/3.53 (5d), 68.2/3.58 + 3.35 (6d), 97.0/4.94 (1e), 68.3/5.43 (2e), 78.3/3.99 (3e), 74.3/3.85 (4e), 71.3/3.90 (5e), 69.0/3.72 (6e). Anal. Calcd for  $\text{C}_{77}\text{H}_{84}\text{O}_{17}\text{Cl}_3\text{N}$  (1401.97): C 65.96, H 6.05, N 1.00. Found: C 65.92, H 6.14, N 0.99.

**Allyl (3,4,6-Tri-*O*-benzyl- $\alpha$ -D-mannopyranosyl)-(1→6)-[(3,4,6-tri-*O*-benzyl-2-deoxy-2-trichloroacetamido- $\beta$ -D-galactopyranosyl)-(1→4)]-2-*O*-allyl-3-*O*-benzyl- $\alpha$ -D-mannopyranoside (23).** Compound **21** (4 g, 2.85 mmol) was dissolved in 0.1 N  $\text{NaOMe}$  solution (15 mL) and 21 mL of dry diethyl ether. After removal of the solvent and flash chromatography (petroleum ether/ethyl acetate 2:1) compound **22** (3.88 g, 2.85 mmol, qu.) was obtained as a colorless foam. TLC [petroleum ether/ethyl acetate (2:1)]  $R_f$  0.20;  $[\alpha]_D^{25} +40$  (c 1.5,  $\text{CDCl}_3$ );  $^1\text{H NMR}$  (250 MHz,  $\text{CDCl}_3$ )  $\delta$  3.30–3.40 (m, 1H), 3.48–3.55 (m, 2H), 3.65–4.14 (m, 19H), 4.17–4.84 (m, 15H), 4.98–5.28 (m, 6H), 5.72–5.93 (m, 2H, allyl), 6.97 (d,  $J_{\text{NH}} = 7.2$  Hz, 1H, NH), 7.12–7.37 (m, 35H, Ph). Anal. Calcd for  $\text{C}_{75}\text{H}_{82}\text{O}_{16}\text{Cl}_3\text{N}$  (1359.93): C 66.24, H 6.09, N 1.03. Found: C 66.03, H 6.23, N 0.93.

**Allyl (2-*O*-Acetyl-3,4-di-*O*-benzyl-6-*O*-tert-butylidiphenylsilyl- $\alpha$ -D-mannopyranosyl)-(1→2)-(3,4,6-tri-*O*-benzyl- $\alpha$ -D-mannopyranosyl)-[(3,4,6-tri-*O*-benzyl-2-deoxy-2-trichloroacetamido- $\beta$ -D-galactopyranosyl)-(1→4)]-2-*O*-allyl-3-*O*-benzyl- $\alpha$ -D-mannopyranoside (24).** Compound **23**

(3.88 g, 2.85 mmol) and trichloroacetimidate **8** (2.80 g, 3.56 mmol) were dissolved in 30 mL of dry diethyl ether under argon. At 0 °C a 0.1 N TMSOTf solution (3.8 mL) was added. After stirring at 0 °C for 15 min, neutralization with triethylamine, and removal of the solvent, flash chromatography (petroleum ether/ethyl acetate 4:1) afforded compound **24** (5.43 g, 2.73 mmol, 96%) as a colorless foam. TLC [petroleum ether/ethyl acetate (3:1)]  $R_f$  0.55;  $[\alpha]_D^{+24}$  (c 1.5,  $\text{CDCl}_3$ );  $^1\text{H NMR}$  (250 MHz,  $\text{CDCl}_3$ )  $\delta$  1.08 (s, 9H,  $^t\text{Bu}$ ), 2.10 (s, 3H, OAc), 3.50–4.12 (m, 24H), 4.15–4.37 (m, 4H), 4.39–4.49 (m, 5H), 4.56–4.68 (m, 7H), 4.72–4.85 (m, 6H, 1c–H, 1e–H), 4.88–5.19 (m, 7H, 1f–H, 1d–H), 5.49 (br s, 1H, 2f–H), 5.66–5.85 (m, 2H, allyl), 6.93 (d,  $J_{\text{NH}} = 6.8$  Hz, 1H, NH), 7.11–7.39 (m, 51H, Ph), 7.67–7.76 (m, 4H, TBDPS); HMQC data ( $^{13}\text{C}$  (150.9 MHz)/ $^1\text{H}$  (600 MHz)) 97.4/4.76 (1c), 75.0/3.70 (2c), 78.1/3.86 (3c), 74.1/4.04 (4c), 70.2/3.68 (5c), 66.4/3.78 + 3.57 (6c), 99.2/4.97 (1d), 56.0/3.94 (2d), 77.6/3.97 (3d), 72.0/3.73 (4d), 73.4/3.52 (5d), 68.4/3.52 + 3.32 (6d), 98.4/4.82 (1e), 73.1/4.08 (2e), 80.4/3.90 (3e), 74.6/3.75 (4e), 72.1/3.79 (5e), 69.6/3.62 (6e), 98.9/5.18 (1f), 68.9/5.49 (2f), 78.0/4.02 (3f), 73.7/4.20 (4f), 73.0/3.74 (5f), 62.7/4.09 + 3.87 (6f). Anal. Calcd for  $\text{C}_{113}\text{H}_{124}\text{O}_{22}\text{Cl}_3\text{NSi}$  (1982.82): C 68.44, H 6.32, N 0.71. Found: C 68.39, H 6.40, N 0.49.

**Allyl (3,4-Di-*O*-benzyl-6-*O*-tert-butylidiphenylsilyl- $\alpha$ -D-mannopyranosyl)-(1 $\rightarrow$ 2)-(3,4,6-tri-*O*-benzyl- $\alpha$ -D-mannopyranosyl)-(1 $\rightarrow$ 6)-[(3,4,6-tri-*O*-benzyl-2-deoxy-2-trichloroacetamido- $\beta$ -D-galactopyranosyl)-(1 $\rightarrow$ 4)]-2-*O*-allyl-3-*O*-benzyl- $\alpha$ -D-mannopyranoside (**25**).** Compound **24** (5.2 g, 2.62 mmol) was dissolved in 8.1 mL of dry diethyl ether and 8.1 mL of dry methanol under argon. After addition of sodium (200 mg, 870  $\mu\text{mol}$ ), the solution was stirred at room temperature for 30 min and the solvent was removed. Flash chromatography (petroleum ether/ethyl acetate 3:1) afforded compound **25** (4.9 g, 2.49 mmol, 95%) as a colorless foam. TLC [petroleum ether/ethyl acetate (3:1)]  $R_f$  0.43;  $[\alpha]_D^{+27}$  (c 1.0,  $\text{CDCl}_3$ );  $^1\text{H NMR}$  (250 MHz,  $\text{CDCl}_3$ )  $\delta$  1.06 (9s, H,  $^t\text{Bu}$ ), 3.28–5.26 (m, 54H), 5.66–5.84 (m, 2H, allyl), 6.89 (d,  $J_{\text{NH}} = 6.8$  Hz, 1H, NH), 7.09–7.42 (m, 51H, Ph), 7.67–7.76 (m, 4H, TBDPS). Anal. Calcd for  $\text{C}_{111}\text{H}_{122}\text{O}_{21}\text{Cl}_3\text{NSi}$  (1940.79): C 68.69, H 6.35, N 0.72. Found: C 68.56, H 6.27, N 0.57.

**Allyl (2-*O*-Acetyl-3,4,6-tri-*O*-benzyl- $\alpha$ -D-mannopyranosyl)-(1 $\rightarrow$ 2)-(3,4-di-*O*-benzyl-6-*O*-tert-butylidiphenylsilyl- $\alpha$ -D-mannopyranosyl)-(1 $\rightarrow$ 2)-(3,4,6-tri-*O*-benzyl- $\alpha$ -D-mannopyranosyl)-(1 $\rightarrow$ 6)-[(3,4,6-tri-*O*-benzyl-2-deoxy-2-trichloroacetamido- $\beta$ -D-galactopyranosyl)-(1 $\rightarrow$ 4)]-2-*O*-allyl-3-*O*-benzyl- $\alpha$ -D-mannopyranoside (**26**).** Compound **25** (5.1 g, 2.62 mmol) and trichloroacetimidate **7** (1.84 g, 2.88 mmol) [120] were dissolved in 32 mL of dry diethyl ether under argon. At room temperature a 0.1 N TMSOTf solution (2.5 mL, 0.25 mmol) was added. After stirring for 15 min, neutralization with triethylamine, and removal of the solvent, flash chromatography (petroleum ether/ethyl acetate 4:1) afforded compound **26** (5.9 g, 2.42 mmol, 92%) as a colorless foam. TLC [petroleum ether/ethyl acetate (3:1)]  $R_f$  0.48;  $[\alpha]_D^{+22}$  (c 1.7,  $\text{CDCl}_3$ );  $^1\text{H NMR}$  (250 MHz,  $\text{CDCl}_3$ )  $\delta$  1.04 (s, 9H,  $^t\text{Bu}$ ), 2.11 (s, 3H, OAc), 3.28–5.16 (m, 65H, 1g–H, 1d–H, 1e–H, 1c–H), 5.36 (br s, 1H, 1f–H), 5.57 (br s, 1H, 2g–H), 5.63–5.83 (m, 2H, allyl), 6.91 (d,  $J_{\text{NH}} = 6.7$  Hz, 1H, NH), 7.03–7.53 (m, 66H, Ph), 7.67–7.77 (m, 4H, TBDPS); HMQC data ( $^{13}\text{C}$  (150.9 MHz)/ $^1\text{H}$  (600 MHz)) 97.3/4.71 (1c), 74.8/3.68 (2c), 78.0/3.85 (3c), 74.0/4.01 (4c), 70.1/3.68 (5c), 66.3/3.77 + 3.57 (6c), 99.2/4.97 (1d), 55.9/3.93 (2d), 77.4/3.98 (3d), 72.0/3.75 (4d), 73.3/3.50 (5d), 68.2/3.51 + 3.30 (6d), 98.3/4.83 (1e), 72.7/4.09 (2e), 80.4/3.87 (3e), 74.8/3.71 (4e), 72.1/3.78 (5e), 69.5/3.62 (6e), 99.9/5.35 (1f), 75.2/4.08 (2f), 79.5/3.94 (3f), 74.1/4.14 (4f), 73.1/3.73 (5f), 62.9/4.03 + 3.87 (6f), 99.8/5.07 (1g), 68.7/5.57 (2g), 78.6/3.99 (3g), 74.0/3.90 (4g), 71.8/3.86 (5g), 68.5/3.58 + 3.47 (6g). Anal. Calcd for  $\text{C}_{140}\text{H}_{152}\text{O}_{27}\text{Cl}_3\text{NSi}$  (2415.37): C 69.61, H 6.36, N 0.58. Found: C 69.16, H 6.36, N 0.47.

**Allyl (2-*O*-Acetyl-3,4,6-tri-*O*-benzyl- $\alpha$ -D-mannopyranosyl)-(1 $\rightarrow$ 2)-(3,4-di-*O*-benzyl-6-*O*-tert-butylidiphenylsilyl- $\alpha$ -D-mannopyranosyl)-(1 $\rightarrow$ 2)-(3,4,6-tri-*O*-benzyl- $\alpha$ -D-mannopyranosyl)-(1 $\rightarrow$ 6)-[(2-acetamido-3,4,6-tri-*O*-benzyl-2-**

**deoxy- $\beta$ -D-galactopyranosyl)-(1 $\rightarrow$ 4)]-2-*O*-allyl-3-*O*-benzyl- $\alpha$ -D-mannopyranoside (**27**).** Compound **26** (1.5 g, 620  $\mu\text{mol}$ ) was dissolved in 47 mL of dry toluene and  $\text{Bu}_3\text{SnH}$  (740  $\mu\text{L}$ , 2.79 mmol) and AIBN (30 mg) were added. After 25 min of vigorous stirring at room temperature under an argon stream the solution was rapidly heated to 110 °C; after 25 min again 500  $\mu\text{L}$  of  $\text{Bu}_3\text{SnH}$  and some AIBN were added, after an additional 15 min again 200  $\mu\text{L}$  of  $\text{Bu}_3\text{SnH}$  and some AIBN. After removal of the solvent and immediate flash chromatography (petroleum ether/ethyl acetate 5:1  $\rightarrow$  5:2) of the residue compound **27** (1.18 g, 505  $\mu\text{mol}$ , 81%) was obtained as a colorless foam. TLC [petroleum ether/ethyl acetate (5:2)]  $R_f$  0.25;  $[\alpha]_D^{+22}$  (c 1.7,  $\text{CDCl}_3$ );  $^1\text{H NMR}$  (250 MHz,  $\text{CDCl}_3$ )  $\delta$  1.03 (s, 9H,  $^t\text{Bu}$ ), 1.68 (s, 3H, NAc), 2.13 (s, 3H, OAc), 3.03–5.16 (m, 65H, see table, 4.70: 1c–H, 4.88: 1e–H, 4.88: 1d–H, 5.09: 1g–H), 5.34 (br s, 1H, 1f–H), 5.58 (br s, 1H, 2g–H), 5.63–5.83 (m, 2H, allyl), 6.19 (d,  $J_{\text{NH}} = 7.6$  Hz, 1H, NH), 7.01–7.35 (m, 66H, Ph), 7.63–7.78 (m, 4H, TBDPS); HMQC data ( $^{13}\text{C}$  (150.9 MHz)/ $^1\text{H}$  (600 MHz)) 97.9/4.70 (1c), 75.5/3.65 (2c), 78.6/3.84 (3c), 75.3/3.97 (4c), 70.2/3.67 (5c), 66.3/3.79 + 3.67 (6c), 101.5/4.88 (1d), 54.4/3.86 (2d), 79.1/3.79 (3d), 72.4/3.63 (4d), 73.6/3.44 (5d), 68.9/3.47 + 3.23 (6d), 98.6/4.88 (1e), 73.2/4.14 (2e), 80.3/3.90 (3e), 75.5/3.50 (4e), 72.6/3.76 (5e), 70.6/3.63 + 3.53 (6e), 100.4/5.34 (1f), 75.6/4.07 (2f), 79.7/3.92 (3f), 74.5/4.14 (4f), 73.6/3.71 (5f), 63.2/4.02 + 3.84 (6f), 100.2/5.09 (1g), 69.1/5.57 (2g), 79.0/3.99 (3g), 74.5/3.89 (4g), 72.2/3.89 (5g), 68.9/3.61 + 3.90 (6g). Anal. Calcd for  $\text{C}_{140}\text{H}_{155}\text{O}_{27}\text{NSi}$  (2312.05): C 72.72, H 6.77, N 0.61. Found: C 72.73, H 6.83, N 0.47.

**Allyl (3,4,6-Tri-*O*-benzyl- $\alpha$ -D-mannopyranosyl)-(1 $\rightarrow$ 2)-(3,4-di-*O*-benzyl-6-*O*-tert-butylidiphenylsilyl- $\alpha$ -D-mannopyranosyl)-(1 $\rightarrow$ 2)-(3,4,6-tri-*O*-benzyl- $\alpha$ -D-mannopyranosyl)-(1 $\rightarrow$ 6)-[(2-acetamido-3,4,6-tri-*O*-benzyl-2-deoxy- $\beta$ -D-galactopyranosyl)-(1 $\rightarrow$ 4)]-2-*O*-allyl-3-*O*-benzyl- $\alpha$ -D-mannopyranoside (**28**).** Compound **27** (890 mg, 385  $\mu\text{mol}$ ) was dissolved in 3.8 mL of dry methanol and 2.7 mL of dry diethyl ether under argon. After addition of sodium (10 mg, 435  $\mu\text{mol}$ ) and stirring at room temperature for 1 h, the solvent was removed. After flash chromatography (petroleum ether/ethyl acetate 5:2) compound **28** (780 mg, 342  $\mu\text{mol}$ , 89%) was obtained as a colorless foam. TLC [petroleum ether/ethyl acetate (3:2)]  $R_f$  0.55;  $[\alpha]_D^{+26}$  (c 2.5,  $\text{CDCl}_3$ );  $^1\text{H NMR}$  (250 MHz,  $\text{CDCl}_3$ )  $\delta$  1.04 (s, 9H,  $^t\text{Bu}$ ), 1.66 (s, 3H, OAc), 2.43 (br s, 1H, OH), 3.19–3.25 (m, 1H), 3.38–4.22 (m, 35H), 4.23–4.92 (m, 24H), 4.93–5.16 (m, 5H), 5.22 (br s, 1H), 5.37 (br s, 1H), 5.59–5.82 (m, 2H, allyl), 6.19 (d,  $J_{\text{NH}} = 7.4$  Hz, 1H, NH), 7.05–7.40 (m, 66H, Ph), 7.65–7.80 (m, 4H, TBDPS). Anal. Calcd for  $\text{C}_{138}\text{H}_{153}\text{O}_{26}\text{NSi}$  (2270.01): C 73.01, H 6.81, N 0.62. Found: C 72.96, H 6.95, N 0.53.

**Allyl (2,3,4,6-Tetra-*O*-benzyl- $\alpha$ -D-mannopyranosyl)-(1 $\rightarrow$ 2)-(3,4-di-*O*-benzyl-6-*O*-tert-butylidiphenylsilyl- $\alpha$ -D-mannopyranosyl)-(1 $\rightarrow$ 2)-(3,4,6-tri-*O*-benzyl- $\alpha$ -D-mannopyranosyl)-(1 $\rightarrow$ 6)-[(2-acetamido-3,4,6-tri-*O*-benzyl-2-deoxy- $\beta$ -D-galactopyranosyl)-(1 $\rightarrow$ 4)]-2-*O*-allyl-3-*O*-benzyl- $\alpha$ -D-mannopyranoside (**29**).** Compound **28** (760 mg, 335  $\mu\text{mol}$ ) was dissolved in 1.8 mL of dry DMF under argon and benzyl bromide (44  $\mu\text{L}$ , 368  $\mu\text{mol}$ ) and sodium hydride (9 mg) were added. After the mixture was stirred for 40 min some methanol was added and the solvent removed. Flash chromatography (petroleum ether/ethyl acetate 5:2) afforded compound **29** (583 mg, 247  $\mu\text{mol}$ , 74%) besides some *N*-*O*-dibenzylated compound (82 mg, 94  $\mu\text{mol}$ , 10%), both as colorless foams. **29**: TLC [petroleum ether/ethyl acetate (3:2)]  $R_f$  0.65;  $[\alpha]_D^{+21}$  (c 1.9,  $\text{CDCl}_3$ );  $^1\text{H NMR}$  (250 MHz,  $\text{CDCl}_3$ )  $\delta$  1.00 (s, 9H,  $^t\text{Bu}$ ), 1.66 (s, 3H, OAc), 3.18–3.24 (m, 1H), 3.38–4.18 (m, 36H), 4.20–4.93 (m, 26H), 4.93–5.15 (m, 4H), 5.25 (br s, 1H), 5.37 (br s, 1H), 5.58–5.80 (m, 2H, allyl), 6.18 (d,  $J_{\text{NH}} = 7.3$  Hz, 1H, NH), 7.00–7.38 (m, 71H, Ph), 7.65–7.78 (m, 4H, TBDPS). Anal. Calcd for  $\text{C}_{145}\text{H}_{159}\text{O}_{26}\text{NSi}$  (2360.14): C 73.79, H 6.80, N 0.59. Found: C 73.67, H 6.72, N 0.46. *N*-*O*-Dibenzyl compound: TLC [petroleum ether/ethyl acetate (3:2)]  $R_f$  0.75;  $[\alpha]_D^{+24}$  (c 1.1,  $\text{CDCl}_3$ );  $^1\text{H NMR}$  (250 MHz,  $\text{CDCl}_3$ )  $\delta$  0.98 (s, 9H,  $^t\text{Bu}$ ), 1.60 (s, 3H, OAc), 3.20–4.18 (m, 33H), 4.20–4.87 (m, 30H), 4.98–

5.18 (m, 5H), 5.25–5.32 (m, 2H), 5.39 (br s, 1H), 5.60–5.85 (m, 2H, allyl), 7.00–7.32 (m, 76H, Ph), 7.62–7.78 (m, 4H, TBDPS). Anal. Calcd for  $C_{152}H_{165}O_{26}NSi$  (2450.27): C 74.50, H 6.80, N 0.57. Found: C 74.54, H 6.76, N 0.45.

**(2,3,4,6-Tetra-*O*-benzyl- $\alpha$ -D-mannopyranosyl)-(1 $\rightarrow$ 2)-(3,4-di-*O*-benzyl-6-*O*-tert-butylidiphenylsilyl- $\alpha$ -D-mannopyranosyl)-(1 $\rightarrow$ 2)-(3,4,6-tri-*O*-benzyl- $\alpha$ -D-mannopyranosyl)-(1 $\rightarrow$ 6)-[(2-acetamido-3,4,6-tri-*O*-benzyl-2-deoxy- $\beta$ -D-galactopyranosyl)-(1 $\rightarrow$ 4)]-3-*O*-benzyl- $\alpha$ / $\beta$ -D-mannopyranose (30 $\alpha$ / $\beta$ ). Compound **29** (590 mg, 250  $\mu$ mol) and Rh(PPh<sub>3</sub>)<sub>3</sub>Cl (65 mg, 70  $\mu$ mol) were dissolved in 19 mL of solvent (toluene/EtOH/H<sub>2</sub>O 20/10/1) and refluxed for 14 h. After cooling the solution was filtered through a pad of Celite and evaporated, and the remaining residue was dissolved in 29 mL of THF/H<sub>2</sub>O 4/1. I<sub>2</sub> (130 mg, 1 mmol) was added and after 30 min the solution was diluted with ethyl acetate and washed with Na<sub>2</sub>S<sub>2</sub>O<sub>3</sub> solution (20% in H<sub>2</sub>O). The aqueous fraction was reextracted three times with ethyl acetate, the combined organic fractions were dried over MgSO<sub>4</sub>, and the solvent was removed. Flash chromatography (petroleum ether/ethyl acetate 2:1  $\rightarrow$  1:1) of the remaining residue afforded compound **30 $\alpha$ / $\beta$**  (498 mg, 218  $\mu$ mol, 87%) as a colorless foam. TLC [petroleum ether/ethyl acetate (2:1)] *R*<sub>f</sub> 0.1; [ $\alpha$ ]<sub>D</sub> 16 (c 1.5, CDCl<sub>3</sub>); <sup>1</sup>H NMR (250 MHz, CDCl<sub>3</sub>)  $\delta$  1.06 (s, 9H, <sup>t</sup>Bu), 1.73 (s, 3H, OAc), 2.35 (br s, 1H, OH), 3.18–3.24 (m, 1H), 3.35–4.93 (m, 57H), 5.07 (d, *J* = 8.5, 1H), 5.33 (br s, 1H), 5.37 (br s, 1H), 6.31 (d, *J*<sub>NH</sub> = 7.2 Hz, 1H, NH), 7.05–7.40 (m, 71H, Ph), 7.63–7.67 (m, 4H, TBDPS). Anal. Calcd for  $C_{139}H_{151}O_{26}NSi$  (2280.00): C 72.61, H 6.72, N 0.61 (+1/2H<sub>2</sub>O). Found: C 72.34, H 6.88, N 0.45.**

**Phenoxyacetyl (2,3,4,6-Tetra-*O*-benzyl- $\alpha$ -D-mannopyranosyl)-(1 $\rightarrow$ 2)-(3,4-di-*O*-benzyl-6-*O*-tert-butylidiphenylsilyl- $\alpha$ -D-mannopyranosyl)-(1 $\rightarrow$ 2)-(3,4,6-tri-*O*-benzyl- $\alpha$ -D-mannopyranosyl)-(1 $\rightarrow$ 6)-[(2-acetamido-3,4,6-tri-*O*-benzyl-2-deoxy- $\beta$ -D-galactopyranosyl)-(1 $\rightarrow$ 4)]-3-*O*-benzyl-2-*O*-phenoxyacetyl- $\alpha$ -D-mannopyranose (31 $\alpha$ / $\beta$ ). Compound **30** (510 mg, 224  $\mu$ mol) was dissolved in 5 mL of pyridine, phenoxyacetyl chloride (180 mL, 1.3 mmol) was added at 0 °C, and the solution was warmed to room temperature and stirred for 14 h. After coevaporation with toluene for 3 times, the remaining residue was put on silica gel by dissolving in CH<sub>2</sub>Cl<sub>2</sub>, adding some silica gel, and evaporation. Flash chromatography (petroleum ether/ethyl acetate 2:1  $\rightarrow$  1:1) afforded compound **31 $\alpha$ / $\beta$**  (460 mg, 180  $\mu$ mol, 81%) as a colorless foam. TLC [petroleum ether/ethyl acetate (3:2)] *R*<sub>f</sub> 0.60  $\alpha$ , 0.33  $\beta$ ; <sup>1</sup>H NMR (250 MHz, CDCl<sub>3</sub>) **31 $\alpha$** ,  $\delta$  1.00 (s, 9H, <sup>t</sup>Bu), 1.65 (s, 3H, OAc), 3.30–4.95 (m, 61H), 5.20 (br s, 1H), 5.31 (dd, *J* = 2.2 Hz, *J* = 5.6 Hz, 1H), 5.38 (br s, 1H), 6.07 (d, *J*<sub>1,2</sub> = 1.9 Hz, 1H, 1-H), 6.64 (d, *J*<sub>NH</sub> = 7.7 Hz, 1H, NH), 6.60–7.40 (m, 81H, Ph), 7.68–7.80 (m, 4H, TBDPS). Anal. Calcd for  $C_{155}H_{163}O_{30}NSi$  (2548.28): C 73.05, H 6.46, N 0.55. Found: C 72.76, H 6.35, N 0.45.**

**(2,3,4,6-Tetra-*O*-benzyl- $\alpha$ -D-mannopyranosyl)-(1 $\rightarrow$ 2)-(3,4-di-*O*-benzyl-6-*O*-tert-butylidiphenylsilyl- $\alpha$ -D-mannopyranosyl)-(1 $\rightarrow$ 2)-(3,4,6-tri-*O*-benzyl- $\alpha$ -D-mannopyranosyl)-(1 $\rightarrow$ 6)-[(2-acetamido-3,4,6-tri-*O*-benzyl-2-deoxy- $\beta$ -D-galactopyranosyl)-(1 $\rightarrow$ 4)]-3-*O*-benzyl-2-*O*-phenoxyacetyl- $\alpha$ -D-mannopyranose (**32**) and *O*-((2,3,4,6-Tetra-*O*-benzyl- $\alpha$ -D-mannopyranosyl)-(1 $\rightarrow$ 2)-(3,4-di-*O*-benzyl-6-*O*-tert-butylidiphenylsilyl- $\alpha$ -D-mannopyranosyl)-(1 $\rightarrow$ 2)-(3,4,6-tri-*O*-benzyl- $\alpha$ -D-mannopyranosyl)-(1 $\rightarrow$ 6)-[(2-acetamido-3,4,6-tri-*O*-benzyl-2-deoxy- $\beta$ -D-galactopyranosyl)-(1 $\rightarrow$ 4)]-3-*O*-benzyl-2-*O*-phenoxyacetyl- $\alpha$ -D-mannopyranosyl) Trichloroacetimidate (**5**). Compound **31** (1.6 g, 628  $\mu$ mol) was dissolved in 60 mL of DMF and stirred with (NH<sub>4</sub>)<sub>2</sub>CO<sub>3</sub> (1.6 g, 20.5 mmol) at 50 °C for 2 h. After removal of the solvent ( $\rightarrow$ **32**) the residue was dissolved in 20 mL of CH<sub>2</sub>Cl<sub>2</sub> and trichloroacetonitrile (500  $\mu$ L, 5 mmol) and 2 drops of DBU were added. After 45 min the solvent was removed and flash chromatography (petroleum ether/ethyl acetate 2:1) afforded compound **5 $\alpha$ / $\beta$**  (1.22 g, 477  $\mu$ mol, 76% over 2 steps) as a colorless foam. **32**: TLC [petroleum ether/ethyl acetate (4:3)] *R*<sub>f</sub> 0.5; <sup>1</sup>H NMR (250 MHz, CDCl<sub>3</sub>)  $\delta$  1.01 (s, 9H, <sup>t</sup>Bu), 1.77 (s, 3H, OAc), 2.95–**

3.04 (m, 1H), 3.32–4.91 (m, 59H), 5.12–5.23 (m, 2H), 5.28 (br s, 1H), 6.47 (d, *J*<sub>NH</sub> = 7.6 Hz, 1H, NH), 6.72–6.90 (m, 2H, PA), 7.02–7.40 (m, 74H, Ph), 7.65–7.78 (m, 4H, TBDPS). Anal. Calcd for  $C_{147}H_{157}O_{28}NSi$  (2414.14): C 72.59, H 6.60, N 0.58 (+H<sub>2</sub>O). Found: C 72.16, H 6.46, N 0.46. **5**: TLC [petroleum ether/ethyl acetate (4:3)] *R*<sub>f</sub> 0.85; [ $\alpha$ ]<sub>D</sub> +15 (c 2.3, CDCl<sub>3</sub>); <sup>1</sup>H NMR (250 MHz, CDCl<sub>3</sub>)  $\delta$  1.00 (s, 9H, <sup>t</sup>Bu), 1.62 (s, 3H, OAc), 3.20–3.25 (m, 1H), 3.48–4.95 (m, 58H), 5.09 (d, *J* = 8.2 Hz, 1H), 5.40 (br s, 1H, 1-H), 5.48 (br s, 1H, 2-H), 6.10 (d, *J*<sub>NH</sub> = 8.0 Hz, 1H, NH), 6.14 (d, *J*<sub>1,2</sub> = 1.8 Hz, 1H, 1c-H), 6.69–6.90 (m, 2H, PA), 7.01–7.40 (m, 74H, Ph), 7.66–7.77 (m, 4H, TBDPS), 8.62 (s, 1H, =NH). Anal. Calcd for  $C_{149}H_{157}O_{28}Cl_3N_2Si$  (2558.51): C 69.94, H 6.20, N 1.10. Found: C 69.55, H 6.14, N 1.02.

**(2-Azido-3,6-di-*O*-benzyl-2-deoxy-4-phenoxyacetyl- $\alpha$ -D-glucopyranosyl)-(1 $\rightarrow$ 6)-2,3,4,5-tetra-*O*-benzyl-1-*O*-(4-methoxybenzyl)-myo-inositol (**34**). Compound **33**<sup>13</sup> (500 mg, 486  $\mu$ mol) was dissolved in 6 mL of pyridine and cooled to 0 °C. Phenoxyacetyl chloride (500  $\mu$ L, 3.6 mmol) was added, and the solution was allowed to warm to room temperature and stirred overnight. After coevaporation with toluene, the residue was dissolved in CH<sub>2</sub>Cl<sub>2</sub>, some silica gel was added, and the solvent was removed. Flash chromatography (petroleum ether/ethyl acetate 9:2) afforded compound **34** (470 mg, 403  $\mu$ mol, 83%) as a colorless foam. TLC [petroleum ether/ethyl acetate (3:1)] *R*<sub>f</sub> 0.55; [ $\alpha$ ]<sub>D</sub> +42 (c 1.8, CDCl<sub>3</sub>); <sup>1</sup>H NMR (250 MHz, CDCl<sub>3</sub>)  $\delta$  2.74 (dd, *J* = 2.8 Hz, *J* = 11.0 Hz, 1H), 3.21 (dd, *J* = 2.6 Hz, *J* = 11.1 Hz, 1H), 3.32 (dd, *J* = 3.7 Hz, *J* = 10.4 Hz, 1H), 3.39 (dd, *J* = 2.2 Hz, *J* = 9.8 Hz, 1H), 3.43 (dd, *J* = 9.2 Hz, 1H), 3.48 (dd, *J* = 2.0 Hz, *J* = 9.6 Hz, 1H), 3.81 (s, 3H, OMe), 3.82–4.35 (m, 8H), 4.35–5.10 (m, 13H), 5.25 (dd, *J* = 9.4 Hz, 1H), 5.79 (d, *J*<sub>1,2</sub> = 3.6 Hz, 1H, 1b-H), 6.72–6.76 (m, 2H, PMB), 6.84–6.88 (m, 2H, PMB), 6.93–6.99 (m, 1H, PA), 7.13–7.42 (m, 34H, Ph). Anal. Calcd for  $C_{70}H_{71}O_{13}N_3$  (1162.44): C 72.32, H 6.17, N 3.62. Found: C 72.26, H 6.12, N 3.15.**

**(2-Azido-3,6-di-*O*-benzyl-2-deoxy-4-phenoxyacetyl- $\alpha$ -D-glucopyranosyl)-(1 $\rightarrow$ 6)-2,3,4,5-tetra-*O*-benzyl-myo-inositol (**35**). Compound **34** (510 mg, 439  $\mu$ mol) was dissolved in 39 mL of CH<sub>3</sub>CN/toluene/H<sub>2</sub>O 91/5/4 and cooled to 0 °C. After addition of ceric(IV) ammonium nitrate (1.22 g, 2.2 mmol) and stirring at 0 °C for 30 min the solution was allowed to warm to room temperature and stirred for another 90 min. The mixture was diluted with ethyl acetate and washed three times with saturated NaHCO<sub>3</sub> solution, and the combined organic fractions were dried over MgSO<sub>4</sub>. After removal of the solvent flash chromatography (petroleum ether/ethyl acetate 3:1) afforded compound **35** (439 mg, 421  $\mu$ mol, 96%) as a colorless foam. TLC [petroleum ether/ethyl acetate (3:1)] *R*<sub>f</sub> 0.32; [ $\alpha$ ]<sub>D</sub> +34 (c 15, CDCl<sub>3</sub>); <sup>1</sup>H NMR (250 MHz, CDCl<sub>3</sub>)  $\delta$  2.86 (d, *J* = 3.1 Hz, *J* = 10.9 Hz, 1H), 2.93 (d, *J*<sub>OH</sub> = 7.6 Hz, 1H, OH), 3.12 (dd, *J* = 3.0 Hz, *J* = 10.9 Hz, 1H), 3.36–3.55 (m, 3H), 3.60–3.69 (m, 1H), 3.89–4.17 (m, 8H), 4.33 (d, *J*<sub>HH</sub> = 11.1 Hz, 1H, CH<sub>2</sub>Ph), 4.53–4.82 (m, 7H), 4.90–5.08 (m, 3H), 5.26 (dd, *J* = 9.5 Hz, 1H), 5.57 (d, *J*<sub>1,2</sub> = 3.6 Hz, 1H, 1b-H), 6.73–6.77 (m, 2H, PA), 6.93–6.99 (m, 1H, PA), 7.16–7.40 (m, 32H, Ph). Anal. Calcd for  $C_{62}H_{63}O_{12}N_3$  (1042.28): C 71.44, H 6.10, N 4.03. Found: C 71.34, H 6.08, N 3.55.**

**(2-Azido-3,6-di-*O*-benzyl-2-deoxy-4-phenoxyacetyl- $\alpha$ -D-glucopyranosyl)-(1 $\rightarrow$ 6)-1-*O*-benzyl-2,3,4,5-tetra-*O*-benzyl-myo-inositol (**36**). Compound **35** (360 mg, 315  $\mu$ mol) and benzoyl cyanide (53 mg, 360 mol) were dissolved in 3.2 mL of dry CH<sub>2</sub>Cl<sub>2</sub> under argon and 1.3 mL of dry triethylamine was added. After stirring for 2 h the solution was diluted with ethyl acetate, washed with saturated NaHCO<sub>3</sub> solution, and dried over MgSO<sub>4</sub>, and then the solvent was removed. Flash chromatography (petroleum ether/ethyl acetate 7:2) afforded compound **36** (318 mg, 277  $\mu$ mol, 88%) as a colorless foam. TLC [petroleum ether/ethyl acetate (2:1)] *R*<sub>f</sub> 0.70; [ $\alpha$ ]<sub>D</sub> +17 (c 2.4, CDCl<sub>3</sub>); <sup>1</sup>H NMR (250 MHz, CDCl<sub>3</sub>)  $\delta$  2.59 (dd, *J* = 2.2 Hz, *J* = 11.0 Hz, 1H), 3.07 (dd, *J* = 2.4 Hz, *J* = 11.0 Hz, 1H), 3.23 (dd, *J* = 3.7 Hz, *J* = 10.3 Hz, 1H), 3.55 (t, *J* = 9.4 Hz, 1H), 3.66 (dd, *J* = 2.1 Hz, *J* = 9.9 Hz, 1H), 3.78–3.86 (m, 1H), 3.78–**

4.05 (m, 3H), 4.12–4.25 (m, 3H), 4.34–4.52 (m, 3H), 4.62–4.75 (m, 5H), 4.76–5.02 (m, 3H), 5.11–5.29 (m, 3H), 5.41 (d,  $J_{1,2} = 3.7$  Hz, 1H, 1b–H), 6.70–6.79 (m, 2H, PA), 6.93–7.00 (m, 1H, PA), 7.12–7.39 (m, 32H, Ph), 7.41–7.51 (m, 2H, Bz), 7.52–7.65 (m, 1H, Bz), 8.01–8.05 (m, 2H, Bz). Anal. Calcd for  $C_{69}H_{67}O_{13}N_3$  (1146.39): C 72.29, H 5.90, N 3.67. Found: C 72.22, H 5.88, N 3.42.

**(2-Azido-3,6-di-O-benzyl-2-deoxy- $\alpha$ -D-glucopyranosyl)-(1 $\rightarrow$ 6)-1-O-benzoyl-2,3,4,5-tetra-O-benzyl-myo-inositol (37).** Compound **36** (234 mg, 204  $\mu$ mol) was stirred at 0 °C for 15 min in 5 mL of MeNH<sub>2</sub> solution (33% in dry ethanol) and the solvent was rapidly removed at room temperature. Flash chromatography (petroleum ether/ethyl acetate 4:1) afforded compound **37** (197 mg, 194  $\mu$ mol, 96%) as a colorless foam. TLC [petroleum ether/ethyl acetate (5:2)]  $R_f$  0.62;  $[\alpha]_D^{25} +5.8$  (c 1.2, CDCl<sub>3</sub>); <sup>1</sup>H NMR (250 MHz, CDCl<sub>3</sub>)  $\delta$  2.00 (d,  $J_{OH} = 3.2$  Hz, 1H, OH), 3.05–3.20 (m, 3H), 3.52–3.72 (m, 4H), 3.80–3.91 (m, 1H), 4.18–4.26 (m, 3H), 4.36–4.49 (m, 2H), 4.65–4.87 (m, 8H), 4.96–5.20 (m, 3H), 5.36 (d,  $J_{1,2} = 3.8$  Hz, 1H, 1b–H), 7.14–7.36 (m, 30H, Ph), 7.43–7.49 (m, 2H, Bz), 7.56–7.63 (m, 1H, Bz), 8.02–8.05 (m, 2H, Bz). Anal. Calcd for  $C_{61}H_{61}O_{11}N_3$  (1012.25): C 72.37, H 6.09, N 4.15. Found: C 72.31, H 5.97, N 3.71.

**(2-Azido-3,6-di-O-benzyl-2-N-(tert-butylloxycarbonyl)amino-2-deoxy- $\alpha$ -D-glucopyranosyl)-(1 $\rightarrow$ 6)-1-O-benzoyl-2,3,4,5-tetra-O-benzyl-myo-inositol (6).** Compound **37** (25 mg, 242  $\mu$ mol) was dissolved in 5 mL of pyridine/water 4/1 and propanedithiol (500  $\mu$ L, 5 mmol) and 10 drops of triethylamine were added. After stirring at 45 °C for 2 days in a tightly closed flask (free amine: TLC [petroleum ether/ethyl acetate (5:2)]  $R_f$  0.05) the solution was coevaporated three times with dry toluene and the residue dissolved in 3 mL of dry toluene. Boc<sub>2</sub>O (370 mg, 1.7 mmol) was added, the solution was stirred at room temperature for 4 h, and the solvent was removed. Flash chromatography (petroleum ether/ethyl acetate 3:1) afforded compound **6** (215 mg, 199  $\mu$ mol, 82%) as a colorless foam. TLC [petroleum ether/ethyl acetate (5:2)]  $R_f$  0.38;  $[\alpha]_D^{25} +12$  (c 1.6, CDCl<sub>3</sub>); <sup>1</sup>H NMR (250 MHz, CDCl<sub>3</sub>)  $\delta$  1.16 + 1.13 (s, 9H, <sup>t</sup>Bu), 2.07 (d,  $J_{OH} = 3.0$  Hz, 1H, OH), 3.18–3.25 (m, 1H, 6b–H), 3.30–3.52 (m, 3H, 3b, 5a, 6'b–H), 3.58–3.75 (m, 2H, 3a, 4b–H), 3.80–4.00 (m, 2H, 2b, 5b–H), 4.14–4.32 (m, 3H, 2a, 4a–H), 4.41–4.72 (m, 9H), 4.75–4.85 (m, 2H), 4.95–5.08 (m, 3H, 1a–H), 5.33 (d,  $J_{1,2} = 3.6$  Hz, 1H, 1b–H), 7.03–7.35 (m, 30H, Ph), 7.38–7.48 (m, 2H, Bz), 7.50–7.61 (m, 1H, Bz), 7.95–8.05 (m, 2H, Bz); HMQC data (<sup>13</sup>C (150.9 MHz)/<sup>1</sup>H (600 MHz)) 75.5/5.03 (1a), 74.3/4.20 (2a), 80.8/3.61 (3a), 81.9/4.17 (4a), 81.5/3.47 (5a), 74.4/4.48 (6a), 98.7/5.33 (1b), 53.4/3.86 (2b), 80.6/3.38 (3b), 70.9/3.70 (4b), 70.5/3.96 (5b), 69.0/3.33 + 3.23 (6b). Anal. Calcd for  $C_{66}H_{71}O_{13}N$  (1086.38): C 72.96, H 6.60, N 1.29. Found: C 72.67, H 6.52, N 1.06.

**(2,3,4,6-Tetra-O-benzyl- $\alpha$ -D-mannopyranosyl)-(1 $\rightarrow$ 2)-(3,4-di-O-benzyl-6-O-tert-butylidiphenylsilyl- $\alpha$ -D-mannopyranosyl)-(1 $\rightarrow$ 2)-(3,4,6-tri-O-benzyl- $\alpha$ -D-mannopyranosyl)-(1 $\rightarrow$ 6)-[(2-acetamido-3,4,6-tri-O-benzyl-2-deoxy- $\beta$ -D-galactopyranosyl)-(1 $\rightarrow$ 4)]-(3-O-benzyl-2-O-phenoxyacetyl- $\alpha$ -D-mannopyranosyl)-(1 $\rightarrow$ 4)-(3,6-di-O-benzyl-2-N-(tert-butylloxycarbonyl)amino-2-deoxy- $\alpha$ -D-glucopyranosyl)-(1 $\rightarrow$ 6)-2,3,4,5-tetra-O-benzyl-1-O-benzoyl-myo-inositol (39).** Compound **6** (90 mg, 83  $\mu$ mol) and trichloroacetimidate **5** (230 mg, 90  $\mu$ mol) were dissolved under argon in 1.3 mL of dry CH<sub>2</sub>-Cl<sub>2</sub> and cooled to 0 °C. After addition of a 0.1 N TMSOTf solution (85  $\mu$ L, 8.5  $\mu$ mol) and stirring at 0 °C for 1 h the solution was neutralized with triethylamine. Removal of the solvent and flash chromatography (petroleum ether/ethyl acetate 3:1) with subsequent MPLC afforded compound **39** (213 mg, 61  $\mu$ mol, 74%), which could be lyophilized from dioxane. TLC [HPTLC, petroleum ether/ethyl acetate (2:1)]  $R_f$  0.63;  $[\alpha]_D^{25} +10$  (c 1.0, CDCl<sub>3</sub>); <sup>1</sup>H NMR (250 MHz, CDCl<sub>3</sub>)  $\delta$  0.98 (s, 9H, <sup>t</sup>Bu), 1.11 (s, 9H, Boc), 1.58 (s, 3H, NAc), 3.10–5.08 (m, 81H), 5.20–5.35 (m, 4H, 1b–H, 1c–H, 1f–H, 1g–H), 5.50 (m, 1H, 2c–H), 6.12 (d,  $J_{NH} = 9.2$  Hz, 1H, NH), 6.51–6.58 (m, 2H, PA), 6.76–6.85 (m, 1H, PA), 6.90–7.55 (m, 109H, Ph), 7.62–7.73

(m, 4H, TBDPS), 8.00–8.05 (m, 2H, Bz); HMQC data (<sup>13</sup>C (150.9 MHz)/<sup>1</sup>H (600 MHz)) 75.1/5.05 (1a), 74.1/4.21 (2a), 80.8/3.61 (3a), 81.9/4.16 (4a), 79.7/3.49 (5a), 75.1/4.45 (6a), 98.6/5.33 (1b), 54.5/3.92 (2b), 81.5/3.48 (3b), 73.3/3.83 (4b), 70.6/3.99 (5b), 68.6/3.30 (6b), 98.1/5.29 (1c), 70.2/5.48 (2c), 75.4/3.75 (3c), 72.9/4.01 (4c), 70.8/3.58 (5c), 66.4/3.80 + 3.16 (6c), 100.8/4.65 (1d), 52.4/4.26 (2d), 81.5/3.48 (3d), 71.9/3.49 (4d), 73.5/3.52 (5d), 68.9/3.48 + 3.30 (6d), 99.3/4.55 (1e), 72.7/4.07 (2e), 80.1/3.80 (3e), 75.4/3.42 (4e), 72.5/3.70 (5e), 70.9/3.63 + 3.49 (6e), 100.2/5.28 (1f), 74.4/4.10 (2f), –/3.88 (3f), 74.3/4.13 (4f), 73.1/3.65 (5f), (6f), 99.6/5.22 (1g), 74.7/3.86 (2g), –/3.88 (3g), 74.7/4.00 (4g), 72.1/3.81 (5g), 68.9/3.56 + 3.48 (6g). Anal. Calcd for  $C_{213}H_{226}O_{40}N_2Si$  (3482.50): C 73.46, H 6.55, N 0.80. Found: C 73.23, H 6.50, N 0.65. MALDI-ToF-MS [positive mode, matrix: 4-nitroaniline with NaI in MeOH]  $m/z$  3504 [M + Na]<sup>+</sup>.

**(2,3,4,6-Tetra-O-benzyl- $\alpha$ -D-mannopyranosyl)-(1 $\rightarrow$ 2)-(3,4-di-O-benzyl- $\alpha$ -D-mannopyranosyl)-(1 $\rightarrow$ 2)-(3,4,6-tri-O-benzyl- $\alpha$ -D-mannopyranosyl)-(1 $\rightarrow$ 6)-[(2-acetamido-3,4,6-tri-O-benzyl-2-deoxy- $\beta$ -D-galactopyranosyl)-(1 $\rightarrow$ 4)]-(3-O-benzyl-2-O-phenoxyacetyl- $\alpha$ -D-mannopyranosyl)-(1 $\rightarrow$ 4)-(3,6-di-O-benzyl-2-N-(tert-butylloxycarbonyl)amino-2-deoxy- $\alpha$ -D-glucopyranosyl)-(1 $\rightarrow$ 6)-2,3,4,5-tetra-O-benzyl-1-O-benzoyl-myo-inositol (40).** Compound **39** (190 mg, 55  $\mu$ mol) was dissolved in 2 mL of THF, 440  $\mu$ L (440  $\mu$ mol) of TBAF solution (1 N in THF), and 25  $\mu$ L (433  $\mu$ mol, 8 equiv) of acetic acid. After stirring at 45 °C for 2 to 6 days, removal of the solvent at room temperature, and flash chromatography (petroleum ether/ethyl acetate 3:1  $\rightarrow$  2:1) compound **40** (137 mg, 43  $\mu$ mol, 75%) was obtained, which could be lyophilized from dioxane. TLC [petroleum ether/ethyl acetate (2:1)]  $R_f$  0.52;  $[\alpha]_D^{25} +15$  (c 0.9, CDCl<sub>3</sub>); <sup>1</sup>H NMR (250 MHz, CDCl<sub>3</sub>)  $\delta$  1.09 (s, 9H, <sup>t</sup>Bu), 1.66 (s, 3H, NAc), 3.20–5.15 (m, 83H), 5.28–5.34 (m, 2H), 5.46 (br s, 1H), 6.12 (d,  $J_{NH} = 8.3$  Hz, 1H, NH), 6.53–6.62 (m, 2H, PA), 6.75–6.82 (m, 1H, PA), 6.87–7.51 (m, 103H, Ph), 8.01–8.04 (m, 2H, Bz). Anal. Calcd for  $C_{197}H_{208}O_{40}N_2$  (3244.07): C 72.93, H 6.48, N 0.86. Found: C 72.71, H 6.38, N 0.60. MALDI-TOF-MS [positive mode, matrix: 4-nitroaniline with NaI in MeOH]  $m/z$  3266 [M + Na]<sup>+</sup>.

**Triethylammonium (2,3,4,6-Tetra-O-benzyl- $\alpha$ -D-mannopyranosyl)-(1 $\rightarrow$ 2)-(3,4-di-O-benzyl-6-O-(2-N-benzoyloxycarbonyl)aminoethyl-phosphonato)- $\alpha$ -D-mannopyranosyl)-(1 $\rightarrow$ 2)-(3,4,6-tri-O-benzyl- $\alpha$ -D-mannopyranosyl)-(1 $\rightarrow$ 6)-[(2-acetamido-3,4,6-tri-O-benzyl-2-deoxy- $\beta$ -D-galactopyranosyl)-(1 $\rightarrow$ 4)]-(3-O-benzyl- $\alpha$ -D-mannopyranosyl)-(1 $\rightarrow$ 4)-(3,6-di-O-benzyl-2-N-(tert-butylloxycarbonyl)amino-2-deoxy- $\alpha$ -D-glucopyranosyl)-(1 $\rightarrow$ 6)-2,3,4,5-tetra-O-benzyl-1-O-benzoyl-myo-inositol (41).** Compound **40** (125 mg, 39  $\mu$ mol), compound **2** (92 mg, 230  $\mu$ mol), and tetrazole (16 mg, 230  $\mu$ mol) were dried in a vacuum for 2 h. After addition of 2.5 mL of dry CH<sub>2</sub>Cl<sub>2</sub>, the solution was stirred at room temperature under argon for 3 h and MCPBA (70%) (56 mg, 230  $\mu$ mol) was added. The solution was stirred for another 2 h and then 2 mL of MeNH<sub>2</sub> solution (33% in dry ethanol) was added. After stirring for an additional hour, removal of the solvent, and flash chromatography (4 g silica gel, toluene/ethyl acetate 95:5  $\rightarrow$  9:1  $\rightarrow$  8:2  $\rightarrow$  7:3  $\rightarrow$  6:4  $\rightarrow$  1:1  $\rightarrow$  1:2) compound **41** (96 mg, 29  $\mu$ mol, 74%) was obtained as a colorless foam. TLC [toluene/ethyl acetate (1:1)]  $R_f$  0.4; <sup>1</sup>H NMR (250 MHz, CDCl<sub>3</sub>/d<sub>4</sub>-MeOH 2:1)  $\delta$  1.11 (s, 9H, <sup>t</sup>Bu), 1.83 (s, 3H, NAc), 2.61–2.73 (m, 2H), 3.18–5.37 (m, 88H), 7.05–7.61 (m, 103H, Ph), 8.01–8.04 (m, 2H, Bz); HMQC data (<sup>13</sup>C (150.9 MHz)/<sup>1</sup>H (600 MHz)) 74.8/5.08 (1a), 73.7/4.23 (2a), 80.4/3.63 (3a), 81.4/4.13 (4a), 79.7/3.50 (5a), –/4.47 (6a), 98.0/5.32 (1b), 54.2/3.79 (2b), 80.3/3.48 (3b), 73.8/4.02 (4b), 70.5/4.04 (5b), 68.4/3.48 (6b), 101.4/5.10 (1c), 68.7/3.86 (2c), 77.3/3.67 (3c), (4c), 71.3/3.64 (5c), 101.5/4.65 (1d), 52.1/4.31 (2d), 81.2/3.51 (3d), 71.8/3.62 (4d), 98.7/4.89 (1e), 73.1/4.11 (2e), 80.1/3.90 (3e), 74.8/3.65 (4e), 71.8/3.80 (5e), 100.0/5.16 (1f), (73.5/4.182f), 79.0/3.87 (3f), 74.2/4.01 (4f), 98.8/5.19 (1g), 74.5/3.84 (2g), 79.2/3.86 (3g), 74.2/4.01 (4g); <sup>31</sup>P NMR (242.94 MHz, CDCl<sub>3</sub>)  $\delta$  –1.43. Anal. Calcd for  $C_{199}H_{214}O_{43}N_3P$  (3367.13): C 69.70, H 6.30, N 1.22. Found: C

69.92, H 6.60, N 1.28. MALDI-ToF-MS [positive mode, matrix: 4-nitroaniline with NaI in MeOH]  $m/z$  3390 [M + Na]<sup>+</sup>, 3411 [M - H + 2Na]<sup>+</sup>, 3562 [M - H + 2Na + NaI]<sup>+</sup>.

**Triethylammonium (2,3,4,6-Tetra-*O*-benzyl- $\alpha$ -D-mannopyranosyl)-(1 $\rightarrow$ 2)-(3,4-di-*O*-benzyl-6-*O*-(2-(*N*-benzylloxycarbonyl)aminoethyl-phosphonato)- $\alpha$ -D-mannopyranosyl)-(1 $\rightarrow$ 2)-(3,4,6-tri-*O*-benzyl- $\alpha$ -D-mannopyranosyl)-(1 $\rightarrow$ 6)-[(2-acetamido-3,4,6-tri-*O*-benzyl-2-deoxy- $\beta$ -D-galactopyranosyl)-(1 $\rightarrow$ 4)]-(3-*O*-benzyl-2-*O*-(2-(*N*-*tert*-butyloxycarbonyl)aminoethyl-phosphonato)- $\alpha$ -D-mannopyranosyl)-(1 $\rightarrow$ 4)-(3,6-di-*O*-benzyl-2-*N*-(*tert*-butyloxycarbonyl)amino-2-deoxy- $\alpha$ -D-glucopyranosyl)-(1 $\rightarrow$ 6)-2,3,4,5-tetra-*O*-benzyl-1-*O*-benzoyl-*myo*-inositol (42).** Compound 41 (60 mg, 18  $\mu$ mol), phosphoramidite 3 (38 mg, 106  $\mu$ mol), and tetrazole (7.5 mg, 105  $\mu$ mol) were dried in a vacuum for 2 h. After addition of 1 mL of dry CH<sub>2</sub>Cl<sub>2</sub> the solution was stirred at room temperature under argon for 2.5 h (TLC: toluene/ethyl acetate (1:1) 0.4  $\rightarrow$  0.55). Then <sup>t</sup>BuOOH solution (3 N in dry toluene, 35  $\mu$ L, 105  $\mu$ mol) was added, the solution was stirred again for 2 h, and 1 mL of MeNH<sub>2</sub> solution (33% in dry ethanol) was added. After stirring for an additional hour, removal of the solvent, and flash chromatography (3 g silica gel, toluene/ethyl acetate/MeOH 4:1:0  $\rightarrow$  2:1:0  $\rightarrow$  1:1:0  $\rightarrow$  1:2:0  $\rightarrow$  1:3:0  $\rightarrow$  1:4:0  $\rightarrow$  1:3:1) compound 42 (49 mg, 14  $\mu$ mol, qu.) was obtained as a colorless foam. TLC [CH<sub>2</sub>Cl<sub>2</sub>/MeOH (9/1)]  $R_f$  0.53; <sup>1</sup>H NMR (250 MHz, magic, NEt<sub>3</sub> salt)  $\delta$  1.11 (s, 9H, <sup>t</sup>Bu), 1.38 (s, 9H, <sup>t</sup>Bu), 1.91 (s, 3H, NAc), 2.61–2.73 (m, 4H), 3.08–5.38 (m, 90H), 7.05–7.61 (m, 103H, Ph), 8.01–8.04 (m, 2H, Bz); <sup>31</sup>P NMR (242.94 MHz, CDCl<sub>3</sub>)  $\delta$  -3.07, -3.49 (not calibrated). C<sub>206</sub>H<sub>228</sub>O<sub>48</sub>N<sub>4</sub>P<sub>2</sub> (3590.32): MALDI-ToF-MS [positive mode, matrix: 4-nitroaniline with NaI in MeOH]  $m/z$  3613 [M + Na]<sup>+</sup>, 3635 [M + 2Na]<sup>+</sup>, 3657 [M + 3Na]<sup>+</sup>, 3807 [M + 2Na + NaI]<sup>+</sup>.

**Bistriethylammonium (2,3,4,6-Tetra-*O*-benzyl- $\alpha$ -D-mannopyranosyl)-(1 $\rightarrow$ 2)-(3,4-di-*O*-benzyl-6-*O*-(2-(*N*-benzylloxycarbonyl)aminoethyl-phosphonato)- $\alpha$ -D-mannopyranosyl)-(1 $\rightarrow$ 2)-(3,4,6-tri-*O*-benzyl- $\alpha$ -D-mannopyranosyl)-(1 $\rightarrow$ 6)-[(2-acetamido-3,4,6-tri-*O*-benzyl-2-deoxy- $\beta$ -D-galactopyranosyl)-(1 $\rightarrow$ 4)]-(3-*O*-benzyl-2-*O*-(2-(*N*-*tert*-butyloxycarbonyl)aminoethyl-phosphonato)- $\alpha$ -D-mannopyranosyl)-(1 $\rightarrow$ 4)-(3,6-di-*O*-benzyl-2-*N*-(*tert*-butyloxycarbonyl)amino-2-deoxy- $\alpha$ -D-glucopyranosyl)-(1 $\rightarrow$ 6)-2,3,4,5-tetra-*O*-benzyl-*myo*-inositol (43).** Compound 42 (55 mg, 15  $\mu$ mol) was dissolved in 500  $\mu$ L of a freshly prepared NaOMe solution (0.1 N in dry MeOH, 50  $\mu$ mol) and 200  $\mu$ L of dry CH<sub>2</sub>Cl<sub>2</sub> under argon and stirred at 40 °C for 24 h. Flash chromatography (CH<sub>2</sub>Cl<sub>2</sub>/MeOH 94:6  $\rightarrow$  9:1) afforded compound 43 (44 mg, 12  $\mu$ mol, 78%), which could be lyophilized from dioxane. TLC [CH<sub>2</sub>Cl<sub>2</sub>/MeOH (9:1)]  $R_f$  0.53; <sup>1</sup>H NMR (250 MHz, magic)  $\delta$  1.23 (s, 9H, <sup>t</sup>Bu), 1.31 (s, 9H, <sup>t</sup>Bu), 1.61 (s, 3H, NAc), 2.81–2.91 (m, 4H), 3.00–5.48 (m, 90H), 7.03–7.41 (m, 100H, Ph); <sup>31</sup>P NMR (242.94 MHz, CDCl<sub>3</sub>)  $\delta$  -0.58, -0.97 (calibrated). C<sub>199</sub>H<sub>224</sub>O<sub>47</sub>N<sub>4</sub>P<sub>2</sub> (3486.21): MALDI-ToF-MS [positive mode, matrix: 4-nitroaniline with NaI]  $m/z$  3509 [M + Na]<sup>+</sup>, 3525 [M + K]<sup>+</sup>, 3547 [M - H + Na + K]<sup>+</sup>.

**Tristriethylammonium (2,3,4,6-Tetra-*O*-benzyl- $\alpha$ -D-mannopyranosyl)-(1 $\rightarrow$ 2)-(3,4-di-*O*-benzyl-6-*O*-(2-(*N*-benzylloxycarbonyl)aminoethyl-phosphonato)- $\alpha$ -D-mannopyranosyl)-(1 $\rightarrow$ 2)-(3,4,6-tri-*O*-benzyl- $\alpha$ -D-mannopyranosyl)-(1 $\rightarrow$ 6)-[(2-acetamido-3,4,6-tri-*O*-benzyl-2-deoxy- $\beta$ -D-galactopyranosyl)-(1 $\rightarrow$ 4)]-(3-*O*-benzyl-2-*O*-(2-(*N*-*tert*-butyloxycarbonyl)aminoethyl-phosphonato)- $\alpha$ -D-mannopyranosyl)-(1 $\rightarrow$ 4)-(3,6-di-*O*-benzyl-2-*N*-(*tert*-butyloxycarbonyl)amino-2-deoxy- $\alpha$ -D-glucopyranosyl)-(1 $\rightarrow$ 6)-2,3,4,5-tetra-*O*-benzyl-*myo*-inositol-1-yl-(di-*O*-benzyl) Phosphate (44).** Compound 43 (65 mg, 19  $\mu$ mol), dibenzyl-*N,N*-diisopropylphosphoramidite (35  $\mu$ L, 131  $\mu$ mol), and tetrazole (16 mg, 228  $\mu$ mol) were dried in a vacuum for 1 h. After addition of 750  $\mu$ L of dry CH<sub>2</sub>Cl<sub>2</sub> the solution was stirred at room temperature under argon for 3 h, <sup>t</sup>BuOOH solution (5.5 N in nonane, 20  $\mu$ L, 110  $\mu$ mol) was added, and the solution was again stirred for 35 min. Removal of the solvent and subsequent flash chromatography (3 g silica gel, CH<sub>2</sub>Cl<sub>2</sub>/MeOH 50:1.5  $\rightarrow$  50:3

$\rightarrow$  50:4.5) afforded compound 44 (62 mg, 16  $\mu$ mol, 90%), which could be lyophilized from dioxane. TLC [CH<sub>2</sub>Cl<sub>2</sub>/MeOH (9/1)]  $R_f$  0.52; <sup>1</sup>H NMR (250 MHz, magic)  $\delta$  1.27 (s, 9H, <sup>t</sup>Bu), 1.41 (s, 9H, <sup>t</sup>Bu), 1.61 (s, 3H, NAc), 2.61–2.73 (m, 4H), 3.08–5.38 (m, 95H), 6.95–7.41 (m, 110H, Ph). C<sub>213</sub>H<sub>237</sub>O<sub>50</sub>N<sub>4</sub>P<sub>3</sub> (3746.45): MALDI-TOF-MS [positive mode, matrix: 4-nitroaniline with NaI]  $m/z$  3785 [M + K]<sup>+</sup>, 3806 [M - H<sup>+</sup> + Na + K]<sup>+</sup>.

**$\alpha$ -D-Mannopyranosyl-(1 $\rightarrow$ 2)-(6-*O*-(aminoethylphosphonato)- $\alpha$ -D-mannopyranosyl)-(1 $\rightarrow$ 2)- $\alpha$ -D-mannopyranosyl-(1 $\rightarrow$ 6)-[(2-acetamido-2-deoxy- $\beta$ -D-galactopyranosyl)-(1 $\rightarrow$ 4)]-(2-*O*-(2-(*N*-*tert*-butyloxycarbonyl)aminoethylphosphonato)- $\alpha$ -D-mannopyranosyl)-(1 $\rightarrow$ 4)-(2-*N*-(*tert*-butyloxycarbonyl)amino-2-deoxy- $\alpha$ -D-glucopyranosyl)-(1 $\rightarrow$ 6)-*myo*-inositol-1-yl Phosphate (45).** Compound 44 (17 mg, 4.5  $\mu$ mol) was dissolved in 2 mL of CH<sub>2</sub>Cl<sub>2</sub>/MeOH 1:4, 10 mg of Pd(OH)<sub>2</sub>C (20%) was added, and the solution was stirred under H<sub>2</sub> at room temperature for 8 h. If necessary the catalyst was removed, the solvent evaporated, and the residue dissolved in H<sub>2</sub>O and hydrogenated again. During hydrogenation, the pH value was controlled to be within the range of 4–6. The solution was filtered through a 45  $\mu$ m syringe filter, neutralized with NH<sub>4</sub>HCO<sub>3</sub>, and purified by P4 gel chromatography ( $l$  = 40 cm,  $d$  = 1.6 cm, 0.03 M NH<sub>4</sub>HCO<sub>3</sub>, 1 mL/min). Compound 45 (7 mg, 4  $\mu$ mol, 95%) was obtained, which could be lyophilized from water. <sup>1</sup>H NMR (250 MHz, D<sub>2</sub>O)  $\delta$  1.28 (s, 18H, <sup>t</sup>Bu), 1.92 (s, 3H, NAc), 3.05–3.30 (m, 4H), 3.32–3.98 (m, 45H), 4.39–4.48 (m, 2H, 2c-H, 1d-H), 4.88 (br s, 1H, 1g-H), 4.93 (br s, 1H, 1e-H), 5.13 (br s, 1H, 1f-H), 5.31 (br s, 2H, 1b-H, 1c-H); HMQC data (<sup>13</sup>C (150.9 MHz)/<sup>1</sup>H (600 MHz)) 75.0/3.97 (1a), 71.4/4.28 (2a), 70.5/3.50 (3a), 72.2/3.59 (4a), 73.5/3.35 (5a), 76.4/3.76 (6a), 96.6/5.38 (1b), 55.3/3.61 (2b), 72.0/3.87 (3b), 77.2/3.59 (4b), 71.2/4.03 (5b), 99.3/5.39 (1c), 74.2/4.40 (2c), 68.0/3.93 (3c), 76.4/3.76 (4c), 71.2/3.79 (5c), 66.8/3.83 + 3.65 (6c), 101.5/4.43 (1d), 52.7/3.84 (2d), 70.6/3.70 (3d), 67.8/3.86 (4d), 75.3/3.63 (5d), 98.7/5.00 (1e), 79.0/3.91 (2e), 70.1/3.91 (3e), 67.0/3.61 (4e), 73.3/3.62 (5e), 100.8/5.20 (1f), 78.2/4.04 (2f), 70.1/3.91 (3f), 66.4/3.74 (4f), 72.2/3.79 (5f), 64.7/4.04 (6f), 102.1/4.97 (1g), 70.0/3.99 (2g), 70.4/3.77 (3g), 66.8/3.55 (4g), 73.2/3.68 (5g); <sup>31</sup>P NMR (242.94 MHz, CDCl<sub>3</sub>)  $\delta$  -0.21, -0.56, -1.50. C<sub>58</sub>H<sub>105</sub>O<sub>48</sub>N<sub>4</sub>P<sub>3</sub> (1719.58): MALDI-TOF-MS [positive mode, matrix:  $\alpha$ -cyano-hydroxymzimtsäure with NaI]  $m/z$  1718 [M]<sup>+</sup>, 1741 [M + Na]<sup>+</sup>, 1761 [M + 2Na - H]<sup>+</sup>.

**$\alpha$ -D-Mannopyranosyl-(1 $\rightarrow$ 2)-(6-*O*-(aminoethyl-phosphonato)- $\alpha$ -D-mannopyranosyl)-(1 $\rightarrow$ 2)- $\alpha$ -D-mannopyranosyl-(1 $\rightarrow$ 6)-[(2-acetamido-2-deoxy- $\beta$ -D-galactopyranosyl)-(1 $\rightarrow$ 4)]-2-*O*-(aminoethyl-phosphonato)- $\alpha$ -D-mannopyranosyl-(1 $\rightarrow$ 6)-(2-amino-2-deoxy- $\alpha$ -D-glucopyranosyl)-(1 $\rightarrow$ 6)-*myo*-inositol-1-yl Phosphate (1c).** Compound 45 (7 mg, 4.1  $\mu$ mol) was stirred in 900  $\mu$ L of TFA and 300  $\mu$ L of H<sub>2</sub>O at room temperature for 5 h. After dilution with water and lyophilization, the residue was purified by P4 gel chromatography ( $l$  = 40 cm,  $d$  = 1.6 cm, 0.03 M NH<sub>4</sub>HCO<sub>3</sub>, 1 mL/min). Compound 1c (5.5 mg, 3.2 mol, 85%) was obtained, which could be lyophilized from water. <sup>1</sup>H NMR (250 MHz, D<sub>2</sub>O)  $\delta$  1.92 (s, 3H, NAc), 3.05–3.14 (m, 4H), 3.15–4.03 (m, 45H), 4.30–4.37 (m, 2H, 2d-H, 2c-H), 4.89 (br s, 1H, 1g-H), 4.93 (br s, 1H, 1e-H), 5.11 (br s, 1H, 1f-H), 5.25 (br s, 1H, 1c-H), 5.43 (br s, 1H, 1b-H); HMQC data (<sup>13</sup>C (150.9 MHz)/<sup>1</sup>H (600 MHz)) 75.3/4.07 (1a), 71.1/4.12 (2a), 70.0/3.49 (3a), 71.8/3.62 (4a), 72.2/3.34 (5a), 76.9/3.83 (6a), 94.7/5.54 (1b), 53.3/3.30 (2b), 69.7/4.02 (3b), 75.8/3.68 (4b), 70.2/4.11 (5b), 59.7/3.78 + 3.74 (6b), 98.9/5.35 (1c), 73.6/4.43 (2c), 67.6/3.96 (3c), 76.9/3.79 (4c), 70.8/3.79 (5c), 66.3/3.84 + 3.67 (6c), 101.2/4.43 (1d), 52.1/3.85 (2d), 70.0/3.70 (3d), 67.2/3.86 (4d), 74.9/3.66 (5d), 66.3/3.84–3.67 (6d), 98.3/5.03 (1e), 78.6/3.92 (2e), 89.6/3.88 (3e), 66.5/3.61 (4e), 72.9/3.63 (5e), 66.3/3.84–3.67 (6e), 100.3/5.19 (1f), 77.7/4.05 (2f), 89.4/3.90 (3f), 65.9/3.71 (4f), 71.7/3.80 (5f), 64.2/4.04 (6f), 101.6/4.98 (1g), 69.6/3.99 (2g), 69.9/3.76 (3g), 66.3/3.56 (4g), 72.8/3.69 (5g), 66.3/3.84–3.67 (6g); <sup>31</sup>P NMR (242.94 MHz, CDCl<sub>3</sub>)  $\delta$  -2.36, -2.61, -3.15 (calibrated with H<sub>3</sub>PO<sub>4</sub>). Anal. Calcd for C<sub>48</sub>H<sub>89</sub>O<sub>44</sub>N<sub>4</sub>P<sub>3</sub> (1519.32): EI-MS (matrix: 2% HOAc/

MeOH 9:1) 1521 [M + H]<sup>+</sup>, MALDI-TOF-MS (positive mode, NBOH) 1518 [M]<sup>+</sup>, 1540 [M + Na]<sup>+</sup>, 1562 [M + 2Na - H]<sup>+</sup>.

**Tristriethylammonium (2,3,4,6-Tetra-*O*-benzyl- $\alpha$ -D-mannopyranosyl)-(1 $\rightarrow$ 2)-(3,4-di-*O*-benzyl-6-*O*-(2-(*N*-benzylloxycarbonyl)aminoethyl-phosphonato)- $\alpha$ -D-mannopyranosyl)-(1 $\rightarrow$ 2)-(3,4,6-tri-*O*-benzyl- $\alpha$ -D-mannopyranosyl)-(1 $\rightarrow$ 6)-[(2-acetamido-3,4,6-tri-*O*-benzyl-2-deoxy- $\beta$ -D-galactopyranosyl)-(1 $\rightarrow$ 4)]-(3-*O*-benzyl-2-*O*-(2-(*N*-tert-butylloxycarbonyl)aminoethyl-phosphonato)- $\alpha$ -D-mannopyranosyl)-(1 $\rightarrow$ 4)-(3,6-di-*O*-benzyl-2-*N*-(tert-butylloxycarbonyl)-amino-2-deoxy- $\alpha$ -D-glucopyranosyl)-(1 $\rightarrow$ 6)-2,3,4,5-tetra-*O*-benzyl-1-*O*-(2-*O*-octadecanoyl-1-*O*-octadecyl-sn-glyceril-phosphonato)-*myo*-inositol (46).** Compound 44 (25 mg, 7.2  $\mu$ mol), phosphoramidite 4 (30 mg, 37  $\mu$ mol), and tetrazole (3 mg, 35  $\mu$ mol) were dried in a vacuum. After addition of 350  $\mu$ L of dry CH<sub>2</sub>Cl<sub>2</sub> the solution was stirred at room temperature under argon for 2.5 h. Then tBuOOH solution (5.5 N in nonane, 7  $\mu$ L, 110  $\mu$ mol) was added and the solution was again stirred for 1 h. A 2.5 mL Me<sub>2</sub>NH solution (33% in dry ethanol) and 2 mL of CH<sub>2</sub>Cl<sub>2</sub> were added. After 1 h the solvent was removed and the residue subjected to flash chromatography (9 g silica gel, CH<sub>2</sub>Cl<sub>2</sub>/MeOH 100:1  $\rightarrow$  50:1  $\rightarrow$  50:1.5  $\rightarrow$  50:2  $\rightarrow$  50:2.5  $\rightarrow$  50:3  $\rightarrow$  50:3.5). Compound 46 (25 mg, 6.1  $\mu$ mol, 83%) was obtained, which could be lyophilized from dioxane/water. TLC [CH<sub>2</sub>Cl<sub>2</sub>/MeOH (9/1)] *R*<sub>f</sub> 0.50; <sup>1</sup>H NMR (250 MHz, magic)  $\delta$  0.87 (t, 6H, CH<sub>3</sub>), 1.43–1.10 (m, 69H), 1.41 (s, 9H, tBu), 1.47–1.63 (m, 4H), 1.67 (s, 3H, NAc), 1.64–1.73 (m, 2H), 2.21–2.41 (m, 4H), 2.78–5.48 (m, 97H), 6.95–7.41 (m, 100H, Ph). C<sub>238</sub>H<sub>301</sub>O<sub>53</sub>N<sub>4</sub>P<sub>3</sub> (4159.34): MALDI-TOF-MS [positive mode, matrix: 4-nitroaniline with NaI] *m/z* 4237 [M - H<sup>+</sup> + 2K]<sup>+</sup>.

**Bistriethylammonium (2,3,4,6-Tetra-*O*-benzyl- $\alpha$ -D-mannopyranosyl)-(1 $\rightarrow$ 2)-(3,4-di-*O*-benzyl-6-*O*-(2-(*N*-benzylloxycarbonyl)aminoethyl-phosphonato)- $\alpha$ -D-mannopyranosyl)-(1 $\rightarrow$ 2)-(3,4,6-tri-*O*-benzyl- $\alpha$ -D-mannopyranosyl)-(1 $\rightarrow$ 6)-[(2-acetamido-3,4,6-tri-*O*-benzyl-2-deoxy- $\beta$ -D-galactopyranosyl)-(1 $\rightarrow$ 4)]-(3-*O*-benzyl-2-*O*-(2-aminoethyl-phosphonato)- $\alpha$ -D-mannopyranosyl)-(1 $\rightarrow$ 4)-(2-amino-3,6-di-*O*-benzyl-2-deoxy- $\alpha$ -D-glucopyranosyl)-(1 $\rightarrow$ 6)-2,3,4,5-tetra-*O*-benzyl-1-*O*-(2-*O*-octadecanoyl-1-*O*-octadecyl-sn-glyceril-phosphonato)-*myo*-inositol (47).** Compound 46 (24 mg, 5.8  $\mu$ mol) was stirred in 1.5 mL of CH<sub>2</sub>Cl<sub>2</sub>/TFA/TES 9:1:0.5 for 1.5 h and evaporated at room temperature. Flash chromatography (2 g silica gel, CH<sub>2</sub>Cl<sub>2</sub>/MeOH 50:1  $\rightarrow$  50:3  $\rightarrow$  50:6  $\rightarrow$  40:20  $\rightarrow$  20:20  $\rightarrow$  20:40) afforded compound 47 (21 mg, 5.2  $\mu$ mol, 90%), which could be lyophilized from dioxane/water. TLC [CH<sub>2</sub>Cl<sub>2</sub>/MeOH (9:1)] *R*<sub>f</sub> 0.46; <sup>1</sup>H NMR (250 MHz, magic)  $\delta$  0.78–1.73 (m, 75H), 2.17–2.28 (m, 4H), 2.89–5.58 (m, 97H), 6.95–7.44 (m, 100H, Ph). C<sub>228</sub>H<sub>285</sub>O<sub>49</sub>N<sub>4</sub>P<sub>3</sub> (3959.08): MALDI-TOF-MS [positive mode, matrix: 4-nitroaniline with NaI] *m/z* 4018 [M - H + Na + K]<sup>+</sup>, 4034 [M - H + 2K]<sup>+</sup>.

**$\alpha$ -D-Mannopyranosyl-(1 $\rightarrow$ 2)-(6-*O*-(aminoethylphosphonato)- $\alpha$ -D-mannopyranosyl)-(1 $\rightarrow$ 2)- $\alpha$ -D-mannopyranosyl-**

**(1 $\rightarrow$ 6)-[(2-acetamido-2-deoxy- $\beta$ -D-galactopyranosyl)-(1 $\rightarrow$ 4)]-(2-*O*-(2-aminoethyl-phosphonato)- $\alpha$ -D-mannopyranosyl)-(1 $\rightarrow$ 4)-(2-amino-2-deoxy- $\alpha$ -D-glucopyranosyl)-(1 $\rightarrow$ 6)-1-*O*-(2-*O*-octadecanoyl-1-*O*-octadecyl-sn-glyceril-phosphonato)-*myo*-inositol (1a).** Compound 47 (16 mg, 4  $\mu$ mol) was dissolved in 1.3 mL of BuOH, 0.5 mL of MeOH, and 200  $\mu$ L of H<sub>2</sub>O, 10 mg of Pd(OH)<sub>2</sub>/C was added, and the suspension was stirred under H<sub>2</sub> for 8 h. The suspension was filtered through a 45  $\mu$ m syringe filter, neutralized with NH<sub>4</sub>HCO<sub>3</sub>, and purified by P4 gel chromatography (*l* = 40 cm, *d* = 1.6 cm, 10% nPrOH in 0.03 M NH<sub>4</sub>HCO<sub>3</sub>, 1 mL/min). Compound 1a (5 mg, 2.4  $\mu$ mol, 60%) was obtained, which could be lyophilized from dioxane/water. <sup>1</sup>H NMR (250 MHz, D<sub>2</sub>O)  $\delta$  0.88–0.97 (m, 6H), 1.18–1.80 (m, 66H), 2.10 (s, 3H, NAc), 2.70–4.26 (m, 83H), 4.50–4.52 (m, 2H, GalNAc-g, Man-c(2)), 5.04 (br s, 1H, Man-f), 5.10 (br s, 1H, Man-d), 5.24 (br s, 1H, Man-e), 5.39 (br s, 1H, Man-c), 5.45 (br s, 1H, GlcN-b). C<sub>87</sub>H<sub>165</sub>O<sub>47</sub>N<sub>4</sub>P<sub>3</sub> (2112.47): MALDI-TOF-MS [positive mode, matrix: 4-nitroaniline with NaI] *m/z* 2136 [M + Na]<sup>+</sup>, 2175 [M + Na + K]<sup>+</sup>.

**Triethylammonium (2,3,4,6-Tetra-*O*-benzyl- $\alpha$ -D-mannopyranosyl)-(1 $\rightarrow$ 2)-(3,4-di-*O*-benzyl-6-*O*-(2-(*N*-benzylloxycarbonyl)aminoethyl-phosphonato)- $\alpha$ -D-mannopyranosyl)-(1 $\rightarrow$ 2)-(3,4,6-tri-*O*-benzyl- $\alpha$ -D-mannopyranosyl)-(1 $\rightarrow$ 6)-[(2-acetamido-3,4,6-tri-*O*-benzyl-2-deoxy- $\beta$ -D-galactopyranosyl)-(1 $\rightarrow$ 4)]-(3-*O*-benzyl-2-*O*-aminoethyl-phosphonato)- $\alpha$ -D-mannopyranosyl)-(1 $\rightarrow$ 4)-(3,6-di-*O*-benzyl-2-amino-2-deoxy- $\alpha$ -D-glucopyranosyl)-(1 $\rightarrow$ 6)-2,3,4,5-tetra-*O*-benzyl-1-*O*-(2-*O*-octadecanoyl-1-*O*-octadecyl-sn-glyceril-phosphonato)-*myo*-inositol (1b).** Compound 45 (49 mg, 11  $\mu$ mol) was dissolved in 1.5 mL of BuOH, 1 mL of MeOH, and 0.5 mL of THF and 10 mg Pd(OH)<sub>2</sub>/C was added. The suspension was stirred under H<sub>2</sub> for 8 h, then filtered through a 45  $\mu$ m syringe filter, neutralized with NH<sub>4</sub>HCO<sub>3</sub>, and purified by P4 gel chromatography (*l* = 40 cm, *d* = 1.6 cm, 10% nPrOH in 0.03 M NH<sub>4</sub>HCO<sub>3</sub>, 1 mL/min). Compound 1b (18.8 mg, 8.2  $\mu$ mol, 75%) was obtained, which could be lyophilized from dioxane/water. C<sub>97</sub>H<sub>181</sub>O<sub>49</sub>N<sub>4</sub>P<sub>3</sub> (2280.73): MALDI-TOF-MS [positive mode, matrix: 4-nitroaniline with NaI] *m/z* 2304 [M + Na]<sup>+</sup>, 2320 [M + K]<sup>+</sup>.

**Acknowledgment.** This work was supported by the Deutsche Forschungsgemeinschaft and Fonds der Chemischen Industrie. K. Pekari is grateful for a Fonds Stipendium.

**Supporting Information Available:** <sup>1</sup>H NMR spectra of all described compounds as well as selected HMQC and mass spectra. This material is available free of charge via the Internet at <http://pubs.acs.org>.

JO026380J